

photodetector module DM0090C data sheet

1 description

The DM0090C photodetector module comprises a 25 mm diameter end-window photomultiplier tube with red sensitive S20 photocathode with low dark counts, a positive high voltage power supply and a high speed amplifier-discriminator. The model includes a counter and micro-controller with USB interface. All are encapsulated within a rectangular metal case with connectors for power input and USB signal output.

2 applications

Intended for ultra-low light measurement applications requiring single photon detection. Utilises a USB interface to a host computer.

3 features

- easy to operate
- compact rectangular assembly
- electrostatic shielding
- operates from low voltage supply
- preset discriminator level and HV
- fully enclosed high voltages
- only 500 mW total power dissipation (typical)
- 70 MHz count rate capability
- wide dynamic range

4 accessories

- adaptor for SMA terminated optical fibre, type DMSMA
- universal ac power adaptor, type CT2PSU
- USB cable with type A male plug

5 characteristics

photocathode type	S20
photocathode active diameter	22 mm
spectral response range	280 to 850 nm, see curve
peak QE at 400 nm	18 %
output	USB
control	see user manual
discriminator level	-2 mV
dark counts at 20 °C (typ.)	1000 s ⁻¹
(max.)	5000 s ⁻¹
power input at 10⁷ s⁻¹	+5 V, 100 mA
warm up time	less than 10 s
input voltage	+4.75 V to +5.25 V
temperature (operating)	+5 °C to +55 °C
(storage)	-40 °C to +55 °C
weight	200 g
operating position	any
finish	case, black powder coat, front plate, black anodised



6 photocathode spectral response

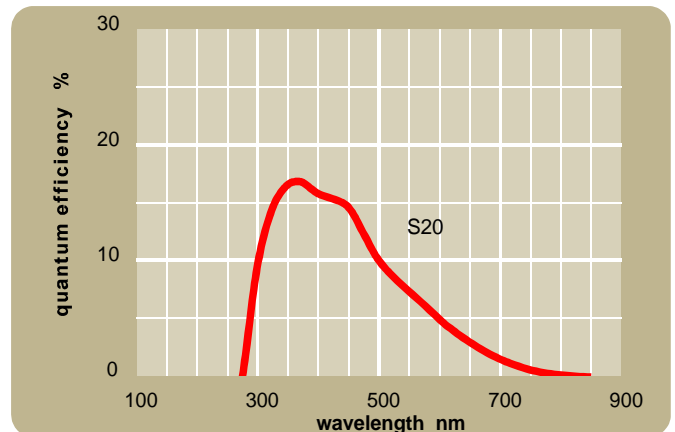

7 user I/O connections

TTL input and output lines are available for control of the module and to command peripheral operations.

trigger input	start command for cycle defined by software
user output	5V logic output for user applications. For example: activate shutter; busy indicator

8 dynamic range

Typical counting sensitivity for DM0090C at 400 nm. Note that automatic dead time correction has been applied at high count rates. The dynamic range can be further extended at low count rates by dark count subtraction in the software.

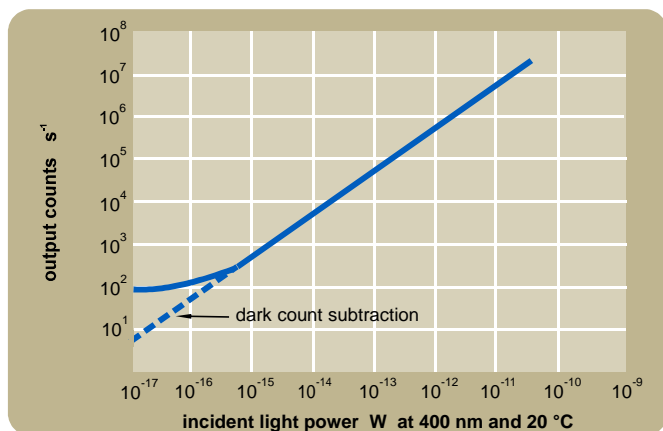

9 functional diagram

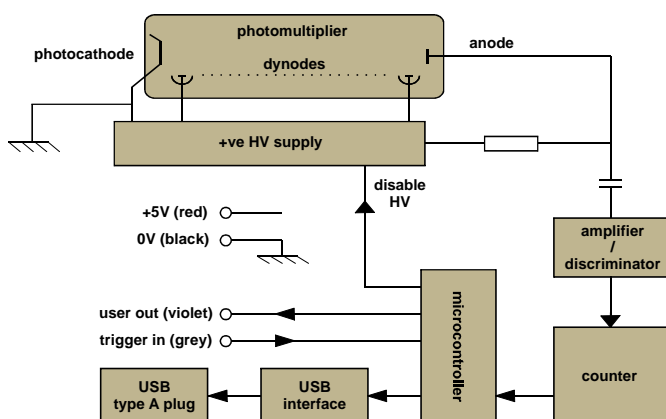

10 outline drawing (mm)

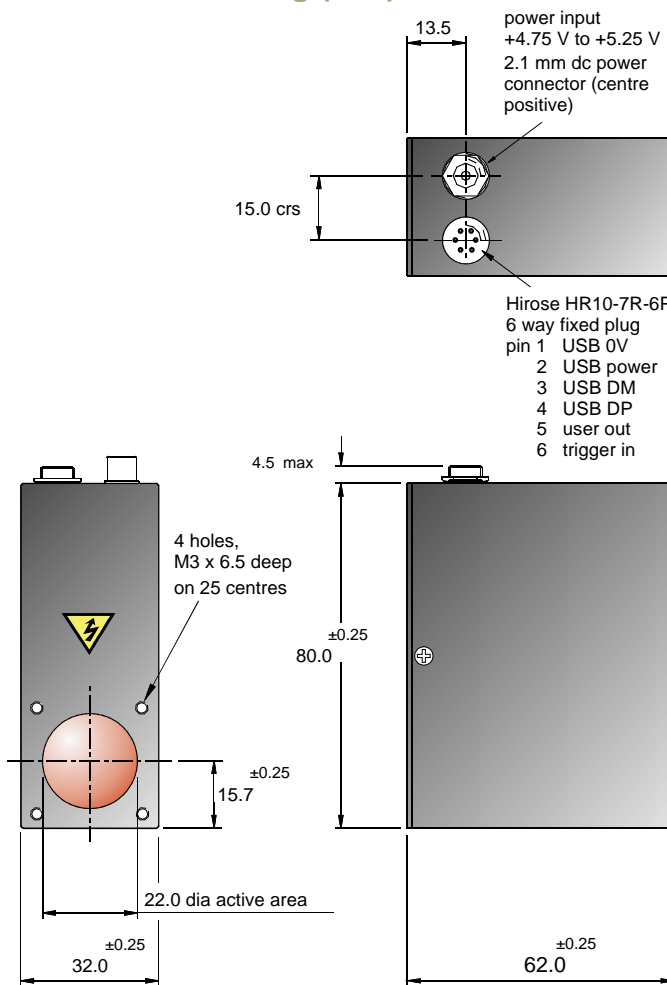

11 installation and operation

Each module is supplied with test data. Wherever possible carry out installation in subdued light.

Remove the protective cap from the window of the module. If necessary, clean the photomultiplier window using a lens tissue moistened with alcohol. Do not use any other solvent. Mount the module and make power input and signal connections.

Do not expose the photomultiplier tube photocathode to strong lights while the module is energised.

12 warning

Do not attempt to repair or dismantle this product. High voltage used within the module presents an electric shock hazard.

Do not operate beyond the maximum ratings, or reverse the input voltage; this may result in loss of performance or permanent damage to the product.