

multi-channel high voltage and control system for photomultipliers HVSys data sheet

1 description

The HVSys is a multi-channel HV power supply system, with individual channel control and monitoring, for powering an array of up to 254 photomultipliers. The system is controlled by a PC with a PCI card and RS485 interface, operating under Windows® 98/NT/XP. The PC performs independent setting and monitoring protocols for voltage, current, and temperature. HV is supplied by individual power bases mounted directly on the base of each photomultiplier. We can provide up to 1800 V with either +HV or -HV as specified at the time of ordering. The power bases use an active voltage divider providing high linear output current with minimum power consumption. The system can be further expanded using additional RS485 cards. Optional temperature monitoring may be used for feedback control or as a safety feature in the event of signal overload.

The HV of any photomultiplier may be set to within 0.5 V and then independently monitored to confirm the actual operating voltage. The software provided allows up to 16 preset voltage settings, current and voltage overload trip setting, and real-time graphical display of current and voltage for every channel.

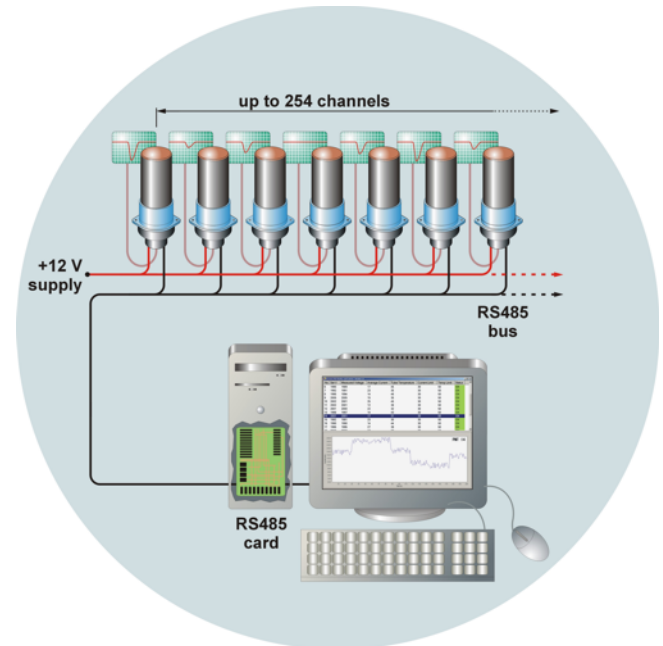

2 applications

HVSys is intended for photomultiplier-based detectors consisting of between 1 and 254 channels. The system finds application in:

- instruments using one or more photomultipliers
- high energy physics
- neutron detectors
- security scanning systems
- astrophysics experiments

3 features

- eliminates expensive and bulky HV cable and connectors
- one PCI card can control up to 254 individual power bases
- system expansion is possible via additional RS485 cards
- programmable options for setting and monitoring parameters
- utilises up to 16 preset voltage settings
- low power consumption per power base
- facility for monitoring temperature or other transducers
- high voltages are restricted to the power supply and photomultiplier - this reduces the electrical shock hazard associated with traditional multi-channel power supplies
- graphical display of parameters
- easy maintenance

4 operational protection and maintenance

The voltage developed by the power base is clamped to a value set by the user; this provides a high degree of protection by preventing possible over-voltages. Similarly, the output current from the power base is also limited to a value set by the software.

System maintenance is straightforward as the software can disable the power base of a single photomultiplier allowing the photomultiplier to be removed and replaced.

5 specification

HV control (programmable)	0 to 1800 V
HV resolution	0.5 V
HV monitor	0 to 1800 V
monitor resolution	0.5 V
current clamp (programmable)	20 - 200 μ A
current monitor	0 - 200 μ A
temperature monitor (optional)	\pm 0.1 $^{\circ}$ C

	unit	min	typ	max
supply voltage	V	11	12	13
supply current ⁽¹⁾	mA		22	
continuous I_a max	μ A			100
HV ripple at anode ⁽²⁾	mV p-p			0.1
HV settling time ⁽³⁾	ms			50
HV discharge time ⁽⁴⁾	ms			500
temperature range	$^{\circ}$ C	+5		+55

(1) at 1 kV, per power base

(2) 100 k Ω //5 pF load

(3) to within 1 %

(4) to 40 V output

6 ordering information

HVSys is customised to individual requirements.

Sens-Tech can provide a power base for any photomultiplier, or an array of different photomultipliers. The photomultiplier type and the application needs to be advised, and we will issue a part number in the HVSys series and a specification for the particular power base. A manual, including the necessary set-up software, is provided with each system.

We offer the PSHVSys, 12 V, 25 A, supply suitable for powering up to 254 channels.

7 system configuration

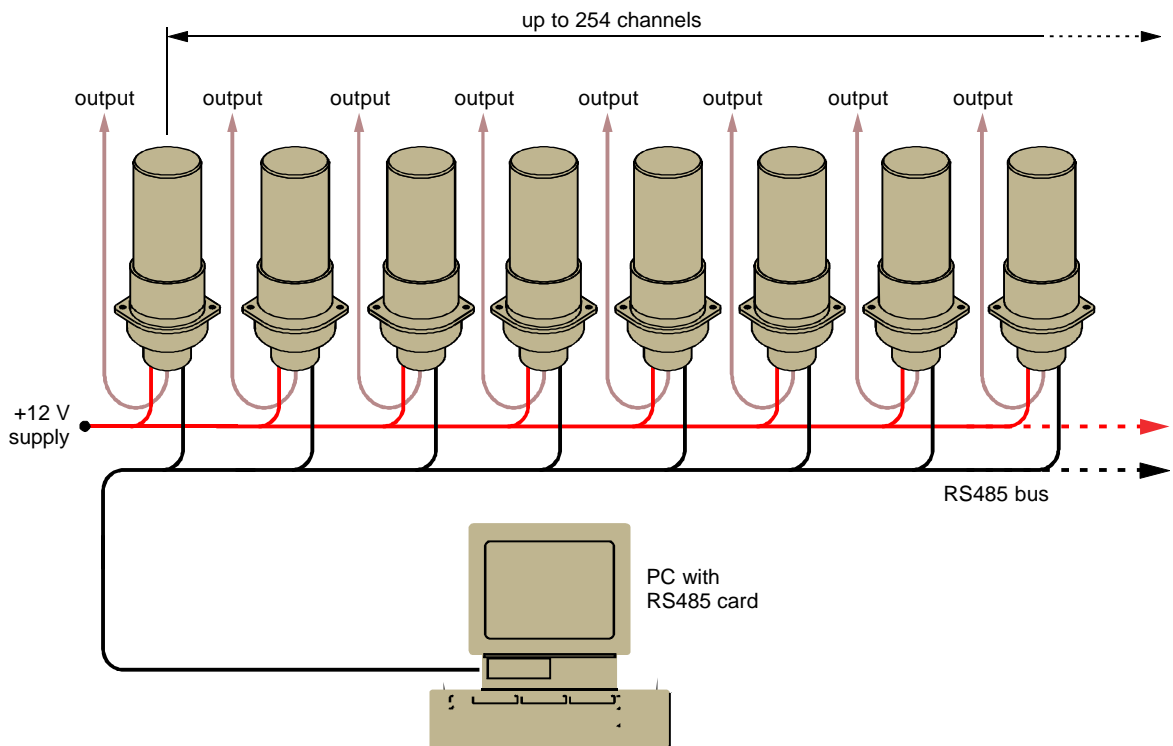

8 functional diagram of one channel

