

LINX linear X-ray sensor data sheet

1 description

LINX is a linear X-ray sensor, using standard Sens-Tech XDAS boards to provide an array of any required length. Detector pitch is 1.6 mm or 0.8 mm. The LINX unit is housed in an aluminium alloy box which is lead screened to protect the electronics from radiation damage. The unit has a collimator with a graphite window, so that only a narrow X-ray beam can reach the detector, reducing scattered radiation and improving image quality.

Data output is in 16 bit format. The system can be interfaced to a PC via:

- USB2
- PCI-7300A data I/O card
- Frame Grabber Card

X-rays are detected using a scintillator and photodiode array. Phosphor strip, CsI (TI) and CdWO₄ are offered to cover the energy range 30 keV to 300 keV.

Data acquisition time can be selected in the range 10 μ s to 50 ms. Read-out rate is fixed at 5 MB/s and the total time is dependent on the number of modules in the system.

2 applications

- ! security
- ! food inspection
- ! process control
- ! thickness measurement
- ! non-destructive testing
- ! material sorting

3 features

- ! wide range of array lengths
- ! 1.6 mm or 0.8 mm detector pitch
- ! range of scintillator types
- ! simultaneous data acquisition and read-out
- ! dual energy option
- ! wide dynamic range
- ! continuous or externally triggered scan
- ! 16 bit output
- ! high speed parallel link to CPU

4 system description

The LINX system uses a data acquisition system made up of XDAS boards. The XDAS system is described in detail on a separate data sheet.

In summary, the XDAS module is a 128 channel data acquisition system with photodiode detector arrays connected to headers mounted on the board. Detector pitch can be either 1.6 mm or 0.8 mm. A dual energy board is available with detectors on both sides of the board. This option is available only with 1.6 mm pitch detectors.

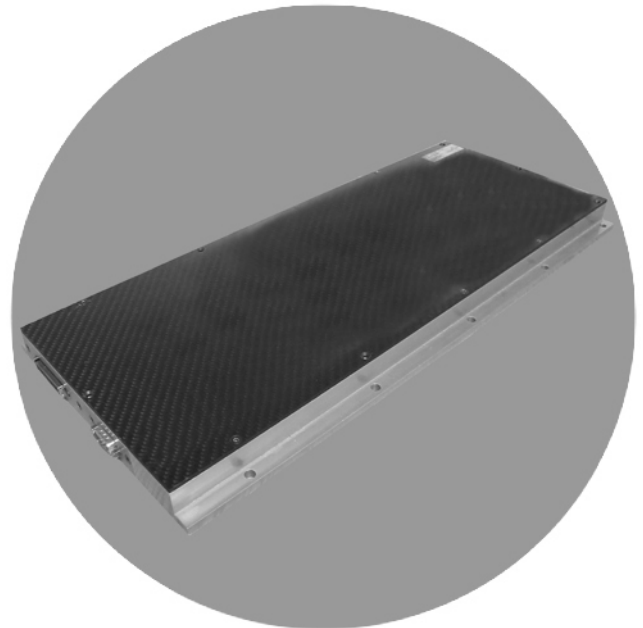

Current from the photodiodes is integrated by a custom designed microcircuit containing 128 charge sensitive amplifiers and a multiplexer. The output is converted to digital format by a 14-bit ADC.

A maximum of either 3 pC or 15 pC of charge can be collected per cycle, depending on the user-selectable gain settings for the front end.

If higher dynamic range is required, a facility for sub-sampling and data summation is incorporated on-board. Up to 4 sub-samples can be acquired and stored in a 16-bit store. When data is ready for transmission, the most significant 16 bits are transmitted via the parallel interface to the host CPU.

User settings to control integration times, sub-sampling and refresh rate, together with information on system configuration are transmitted via an RS485 interface and stored in non-volatile RAM so that on switch-on, the system is initiated in the last mode saved.

5 general specification

integration time (single sample)	10 μ s to 50 ms
sub-samples	4 max
integration time (multiple samples)	200 ms max
signal-to-noise	30000:1
non-linearity	<0.1 % over 10 pC
maximum read-out rate	10 MB/s
A/D conversion	14 bit
data output	16 bit
detector pitch	1.6 mm or 0.8 mm
RS485 Interface	9600 baud, 7 data, odd parity, 1 stop bit

6 environmental specification

operating temperature	+ 5 to + 40 $^{\circ}$ C
storage temperature	-40 to + 70 $^{\circ}$ C
humidity (non-condensing)	
operating	93 % at 40 $^{\circ}$ C

7 configurations supplied

LINX can be supplied in several different configurations, with the options listed below. Variants are as follows:

array dimensions:

Arrays are made up of XDAS boards which have either 64 x 1.6 mm pitch detectors or 128 x 0.8 mm pitch detectors. A dual energy version is available with 64 high energy and 64 low energy detectors on 1.6 mm pitch.

Standard configurations are available with 4, 6, 8, or 10 boards but arrays of other lengths can also be supplied.

scintillator types:

Phosphor strip, CsI (TI), Silicon and CdWO₄ are available. The selection depends primarily on X-ray energy but CdWO₄ has the advantage of very low afterglow which is important for high speed applications.

communications interface:

LINX can be interfaced to a PC using either USB2 or a data I/O card, type PCI-7300A. Control interface is via the PC serial port.

The PCI-7300A card or USB2 provide the full 5 MB/s read-out capability of the system and is recommended for large systems or where fast data acquisition and read-out is required.

A cable set is supplied for the communications interface selected.

Additionally, LINX can be interfaced to the majority of commercially available Frame Grabber cards. Please contact Sens-Tech for further details.

8 ordering information

The following standard configurations are available. Other array lengths and dual energy versions can also be supplied.

part number	array length mm	number of channels	detector pitch mm	scintillator	
LINX-1104	409.6	256	1.6	Gadox	
LINX-1106	614.4	384	1.6	Gadox	
LINX-1108	819.2	512	1.6	Gadox	
LINX-1110	1024	640	1.6	Gadox	
LINX-1204	409.6	256	1.6	CsI (TI)	
LINX-1206	614.4	384	1.6	CsI (TI)	
LINX-1208	819.2	512	1.6	CsI (TI)	
LINX-1210	1024	640	1.6	CsI (TI)	
LINX-1304	409.6	256	1.6	CdWO ₄	
LINX-1306	614.4	384	1.6	CdWO ₄	
LINX-1308	819.2	512	1.6	CdWO ₄	
LINX-1310	1024	640	1.6	CdWO ₄	
LINX-2104	409.6	512	0.8	Gadox	
LINX-2106	614.4	768	0.8	Gadox	
LINX-2108	819.2	1024	0.8	Gadox	
LINX-2110	1024	1280	0.8	Gadox	
LINX-2204	409.6	512	0.8	CsI (TI)	CABLE - XDAS USB - cable set for USB2 interface
LINX-2206	614.4	768	0.8	CsI (TI)	
LINX-2208	819.2	1024	0.8	CsI (TI)	CABLE - XDAS 7300 - cable set for PCI-7300A card
LINX-2210	1024	1280	0.8	CsI (TI)	
LINX-2304	409.6	512	0.8	CdWO ₄	CABLE - XDAS DFG - cable set for frame grabber card
LINX-2306	614.4	768	0.8	CdWO ₄	
LINX-2308	819.2	1024	0.8	CdWO ₄	
LINX-2310	1024	1280	0.8	CdWO ₄	XDAS - SOFTWARE - evaluation software

10 XDAS module block diagram

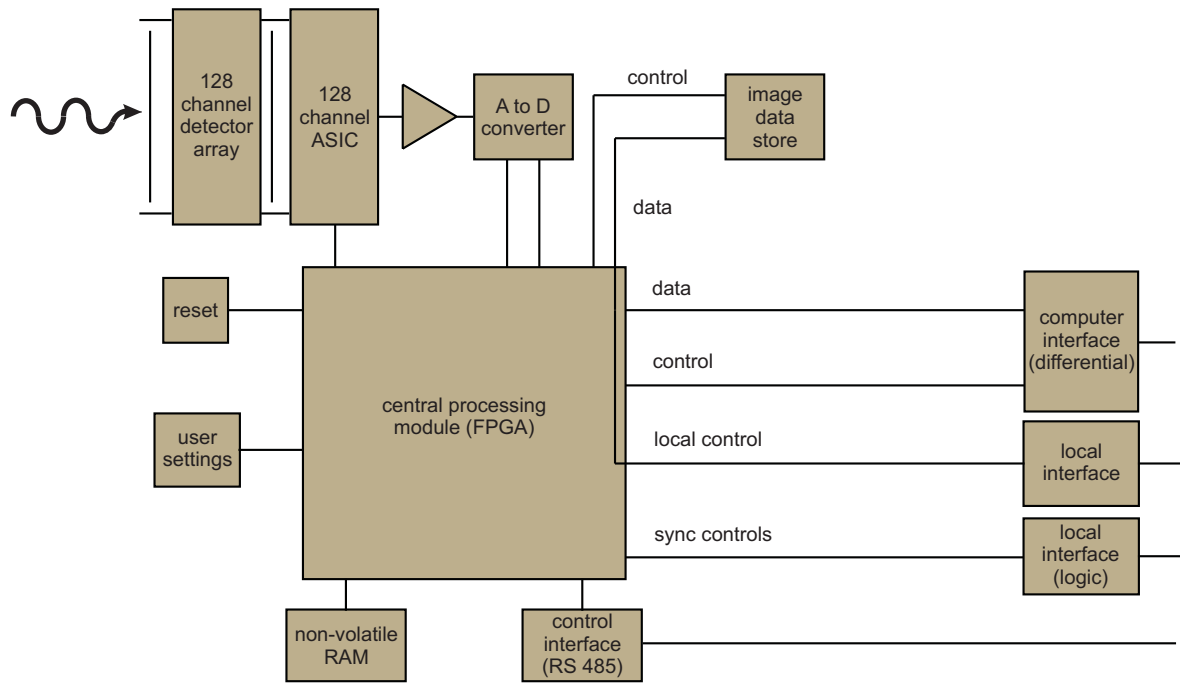

11 LINX system block diagram

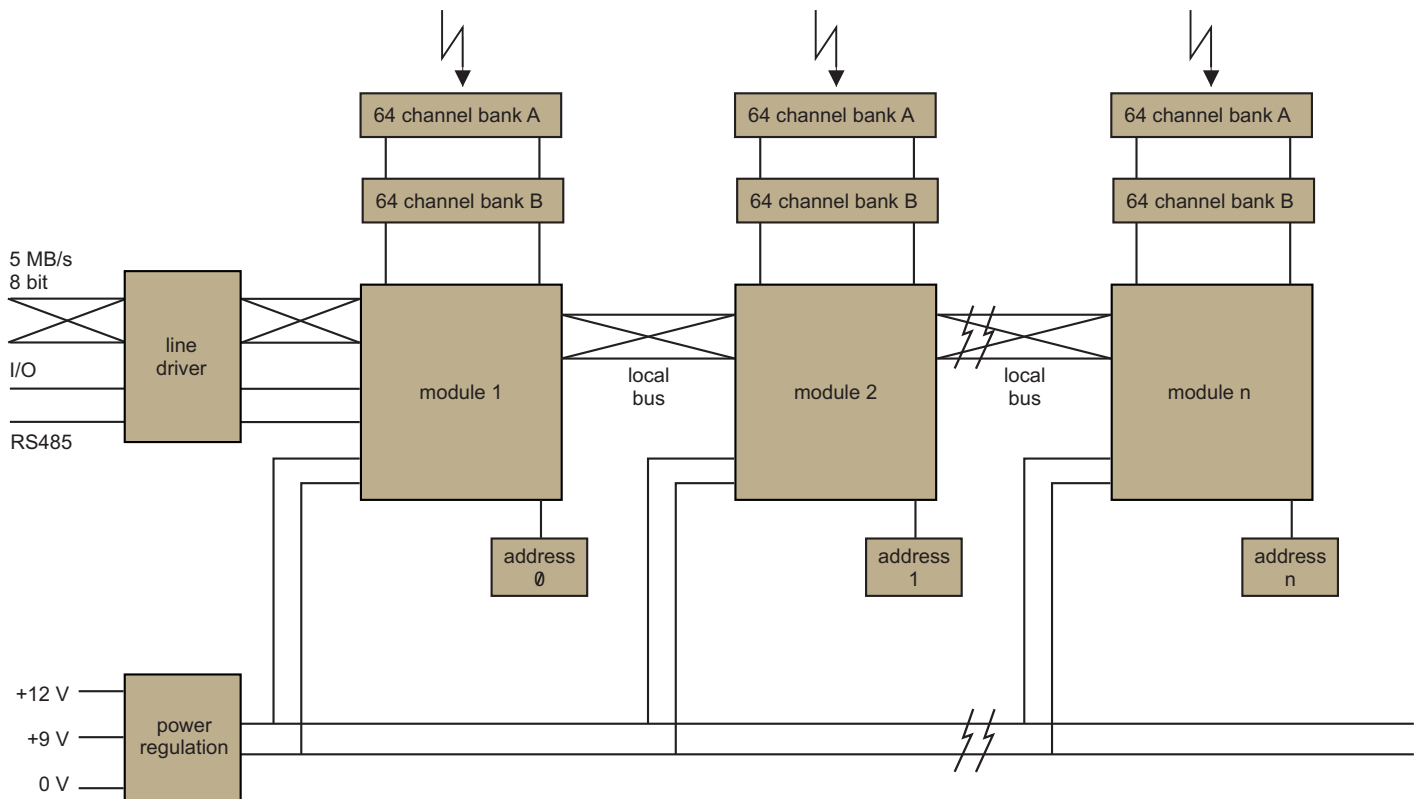

12 system drawing (LINX-2104)

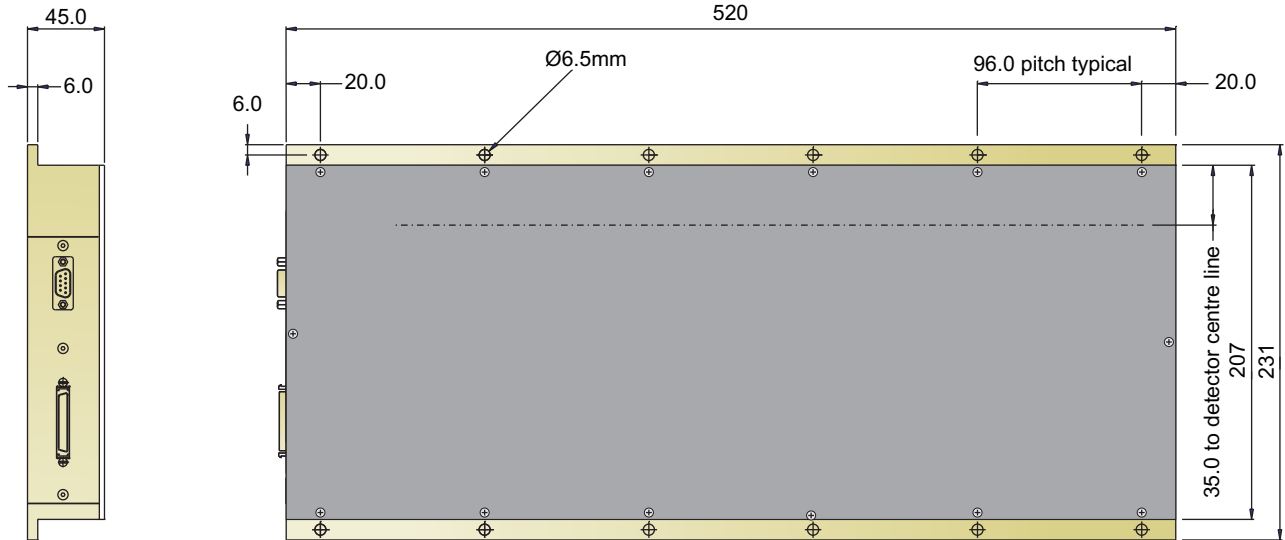

50 way connector pin connections

pin no.	designation	description	signal type
1 to 5	GND	ground	-
6 and 7	LVL+ LVL-	line valid	RS485
8 and 9	D6- D6+	data bit 6	RS485
10 and 11	D5- D5+	data bit 5	RS485
12	NC	no connection	-
13 and 14	D4+ D4-	data bit 4	RS485
15 and 16	D7+ D7-	data bit 7	RS485
17 and 18	D2- D2+	data bit 2	RS485
19 and 20	D1- D1+	data bit 1	RS485
21	D0+		
22	NC	no connection	-
23	D0-	data bit 0	RS485
24 and 25	D3- D3+	data bit 3	RS485
26	FVL-	frame valid	RS485
27	PCK+	pixel clock	RS485
28	FVL+	frame valid	RS485
29	PCK-	pixel clock	RS485
30 to 45	NC	no connection	-
46 to 50	+5 V	5 V power for XDAS-488TTL	

9 way connector pin connections

pin no.	designation	description	signal type
1 to 3	GND	ground	DC
4 and 5	+12 V	12 V power	DC
6	nSCAN	nSCAN	TTL
7 to 9	+9 V	9 V power	DC

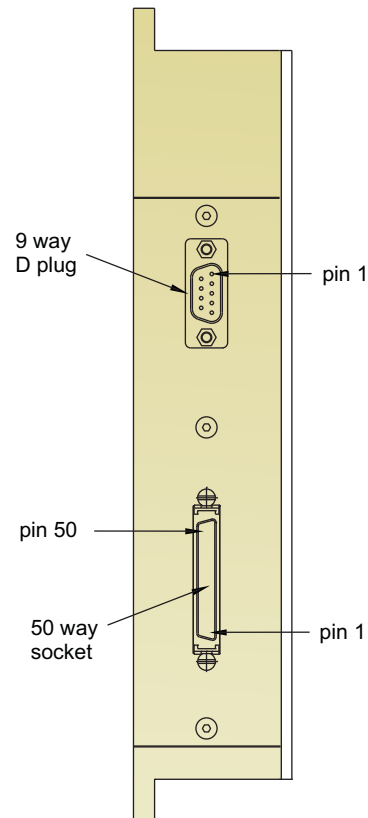

Sens-Tech Limited
6A Langley Business Centre,
Station Road, Langley
Berkshire, SL3 8DS, UK
tel: +44 (0)1753 214714
fax: +44 (0)1753 214715
e-mail: info@sens-tech.com

The company reserves the right to modify these designs and specifications without notice. Developmental devices are intended for evaluation and no obligation is assumed for future manufacture. While every effort is made to ensure accuracy of published information the company cannot be held responsible for errors or consequences arising therefrom.

an ISO 9001 registered company
www.sens-tech.com



© Sens-Tech Limited, 2007
DS_LINX Issue 2
2 November 2007