

# photodetector module P25PVN series

## 1 description

The P25N series is a range of photodetector modules that can be used for all three modes of photomultiplier operation - pulse counting, analogue detection or photon counting.

Each comprises a selected 25 mm diameter end-window photomultiplier tube with a 22 mm effective photocathode diameter, and an active voltage divider powered by an efficient -HV power supply. A photomultiplier with a bialkali photocathode is used for blue-green detection, and an S20 photocathode is used for red detection. All are encapsulated within a cylindrical mumetal\* case, providing a high level of immunity from the effects of external magnetic fields.

The signal lead is connected directly to the anode of the photomultiplier, allowing the freedom to work these modules into a range of electronic circuitry. The -HV is set by applying an external voltage, one-thousandth of the required voltage, to the control input.



## 2 applications

These detectors are suitable for portable, battery powered instruments. They are also desirable for university research and industrial prototype instrument development.

## 3 features

- compact cylindrical geometry
- direct connection to the photomultiplier anode
- electrostatic and magnetic shielding
- standard window: borosilicate
- uv window option

## 4 photocathode spectral response

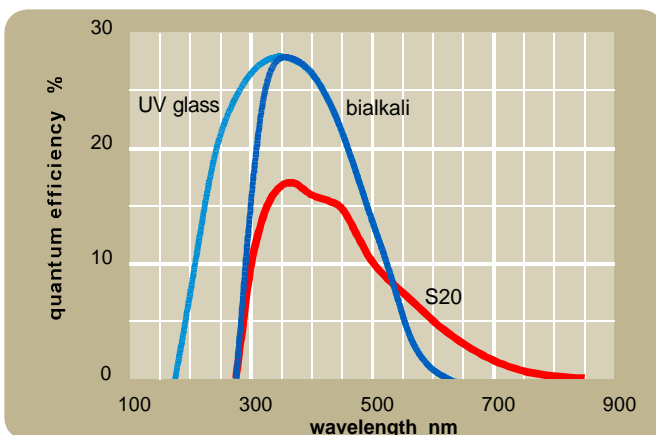

## 5 characteristics

photocathode type	bialkali or S20
photocathode active diameter	22 mm
spectral response range	see curves
peak QE (typ)	see curves
dc linearity ( $\pm 2\%$ )	0 to 100 $\mu$ A
output pulse into 50 $\Omega$ terminated cable	
single electron rise time	1.8 ns
single electron pulse width (fwhm)	3.1 ns
pulse output linearity $\pm 5\%$	0 to 5 mA
power input (typ) <sup>(1)</sup>	+5 V, 60 mA
HV control voltage ratio	1000 : 1
warm up time	10 s
temperature (operating)	+5 $^{\circ}$ C to +55 $^{\circ}$ C
(storage)	-40 $^{\circ}$ C to +55 $^{\circ}$ C
weight	230 g
operating position	any
finish	matt black

<sup>(1)</sup> actual power dissipation depends on HV setting and anode current

## 6 frequency response into 50 $\Omega$

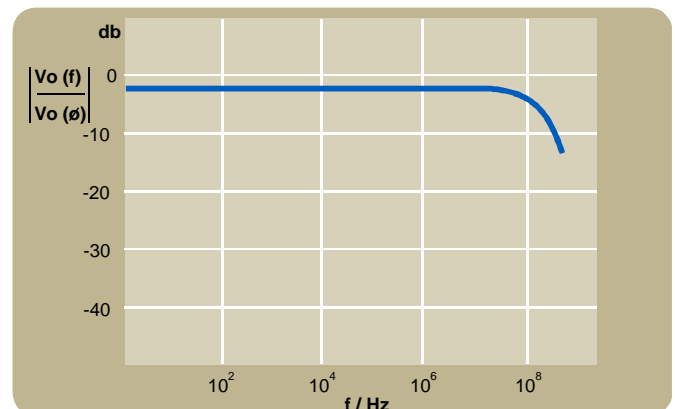

## 7 installation and operation

Each module is supplied with test data. Wherever possible carry out installation in subdued light. Exposure to strong lights, particularly those containing a high uv content, can result in a temporary increase in dark counts during subsequent operation.

Remove the protective cap from the module. If necessary, clean the photomultiplier window using a lens tissue moistened with alcohol. Do not use any other solvent.

Mount the module and make power input and signal connections. Do not expose the photomultiplier tube photocathode to strong lights while the module is energised.

The internal high voltage supply to the photomultiplier tube can be controlled using the internal pot, accessed from the back face of the package, or by applying an external control voltage. Make connections to the yellow (pot) and white (control) wires, as shown in the table below, according to your choice of control method.

When using the internal pot the photomultiplier tube high voltage is increased by clockwise rotation. Monitor the photomultiplier tube high voltage with a voltmeter connected between the white (control) and black (0V) wires. The photomultiplier tube voltage is 1000 x the voltage on the control (white) wire. Take care not to exceed the maximum rated voltage for the photomultiplier tube, as specified in the package test data.

Output pulses from this module are extremely fast and proper termination of the output coaxial cable is required. The shortest possible lead length between the module and external electronics is always advised and good earthing procedures must be respected. Where the signal lead is longer than 200 mm, it should be terminated into 50 Ω. These precautions are particularly relevant when low threshold discriminators are employed.

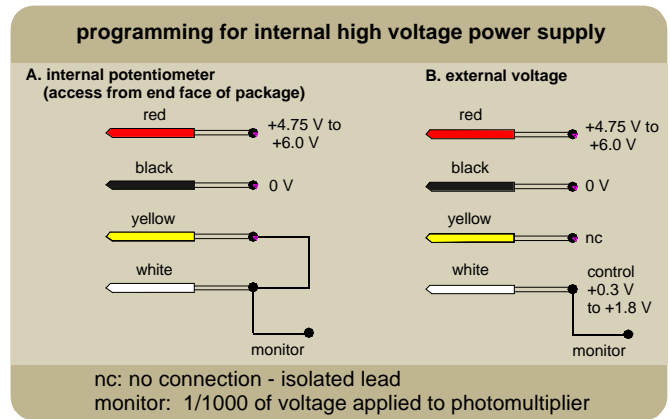

## 8 outline drawing mm

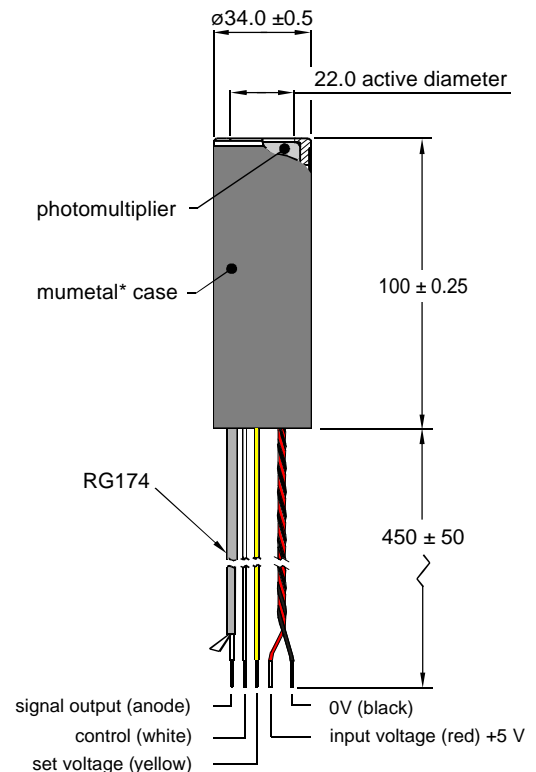

## 9 warning

The photomultiplier cathode is operated at -HV. To guarantee stable performance and for safety reasons, isolate the entire window by a distance of at least 3 mm from any ground plane or components. The use of PTFE for insulation is recommended.

Do not attempt to repair or dismantle this product. High voltage used within the module presents an electric shock hazard.

Do not operate beyond the maximum ratings, or reverse the input voltage; this may result in loss of performance or permanent damage to the product.

\*mumetal is a registered trademark of Magnetic Shield Corporation

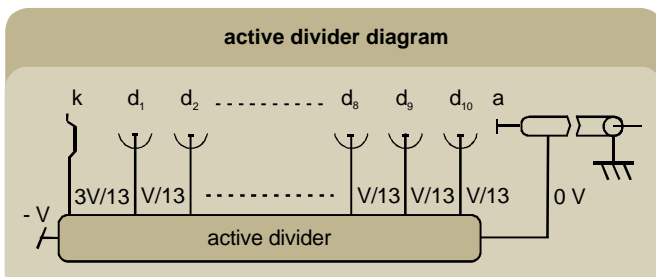
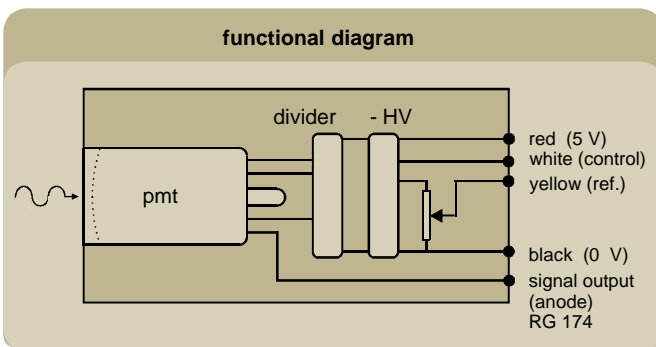

**Sens-Tech Limited**  
6A Langley Business Centre,  
Station Road, Langley  
Berkshire, SL3 8DS, UK  
tel: +44 (0)1753 214714  
fax: +44 (0)1753 214715  
e-mail: info@sens-tech.com

The company reserves the right to modify these designs and specifications without notice. Developmental devices are intended for evaluation and no obligation is assumed for future manufacture. While every effort is made to ensure accuracy of published information the company cannot be held responsible for errors or consequences arising therefrom.

**an ISO 9001 registered company**  
**www.sens-tech.com**



© Sens-Tech Limited, 2010  
DS\_P25PVN series Issue 1  
14 January 2010