

# photomultiplier power base (negative) PS1807 data sheet

## 1 description

The PS1807 is a compact photomultiplier power base incorporating a negative high voltage supply and an active voltage divider. It is suitable for use with 10 stage, 25 mm diameter, hardpin photomultipliers with an overall voltage range of -100 to -1800 V. It is available in two versions: the PS1807/5 operates from a +5 V supply and the PS1807/12 requires +12 V.

It is housed in a cylindrical metal enclosure to provide electrical screening. Low voltage connections are by 500 mm long insulated leads, and the anode output is via a 500 mm long RG174U screened coaxial cable.

The internal high voltage provides power to an active divider, comprising a series of lower power FETs. The dynode potentials are provided directly to the socket contacts.

The overall operating voltage for the photomultiplier can be precisely set using any one of the three programming options shown in section 9.



Examples of the Sens-Tech's range of power bases

## 2 applications

The PS1807 is suitable for the following applications:

- analogue
- pulsed light
- photon counting

## 3 features

- compact design
- freedom from high voltage cables
- extremely low ripple
- exceptional voltage divider stability with varying anode current
- excellent pulse height linearity
- sleep mode

## 4 specification

input power at $V_{max} = -1800$ V	+5 V, 65 mA
power conversion efficiency, $P_o / P_{in}$	40 % for +5 V
input power at $V_{max} = -1800$ V	+12 V, 20 mA
power conversion efficiency, $P_o / P_{in}$	50 % for +12 V
output voltage range	-100 V to -1800 V
line regulation	0.05 % / V
temperature coefficient	<0.02 % °C <sup>-1</sup>
warm up time to 0.3 % of final o/p	< 2 s
discharge time to <40 V with no load	< 2 s
maximum anode current, continuous	100 µA
anode ripple with 100 k //5 pF load	100 µV
weight	60 g

## 5 ratings

input voltage (PS1807/5)	+4.75 V to +6.0 V
input voltage (PS1807/12)	+12 V to +15 V
control voltage	0 to +1.8 V
temperature (operating)	+ 5 °C to +55 °C

## 6 schematic diagram

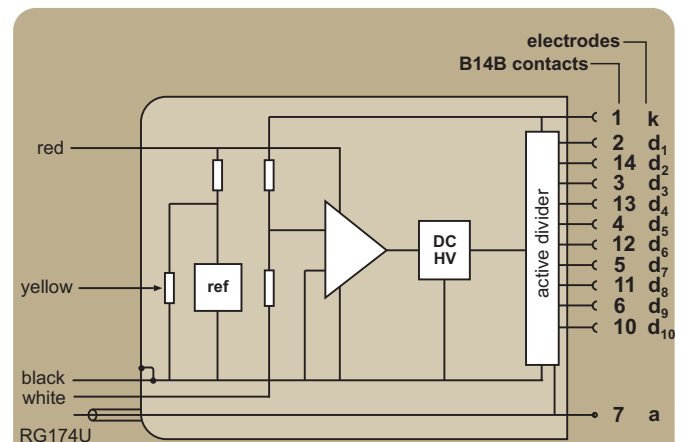

example of output voltage with 1.300 volts applied to control (white) wire

contact	electrode	voltage	contact	electrode	voltage
1	k	-1300	8	nc	-
2	d <sub>1</sub>	-1000	9	nc	-
3	d <sub>3</sub>	-800	10	d <sub>10</sub>	-100
4	d <sub>5</sub>	-600	11	d <sub>8</sub>	-300
5	d <sub>7</sub>	-400	12	d <sub>6</sub>	-500
6	d <sub>9</sub>	-200	13	d <sub>4</sub>	-700
7	a	floating	14	d <sub>2</sub>	-900

nc - no connection

## 7 voltage distribution

The photomultiplier pin configuration compatible with this power base is given below. Note that an anode load resistor is not included.

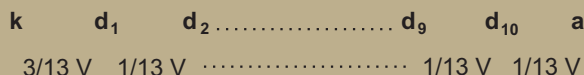
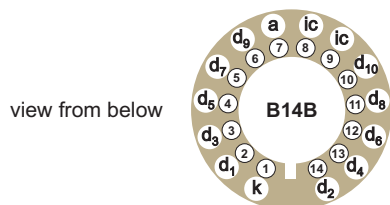

note: V is the high voltage, HV

## 8 sleep mode

The power consumption can be reduced by half to one third of its normal level by activating the sleep mode. This is done by taking the control voltage (white) to 0 V.

## 9 programming options

### 1) internal potentiometer (access from back of power supply, clockwise to increase HV)

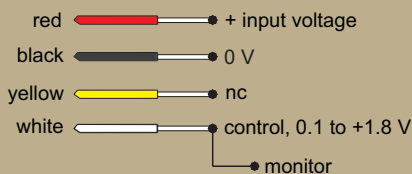
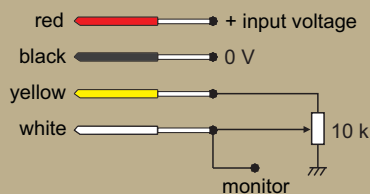
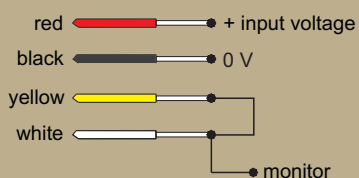

nc: no connection - isolated lead

voltage monitor: 1/1000 of the HV applied to photomultiplier

## 10 outline drawing (mm)

All input connections are 7/0.2 PVC covered, 0.5 m in length. The anode lead is RG174U, also 0.5 m in length.

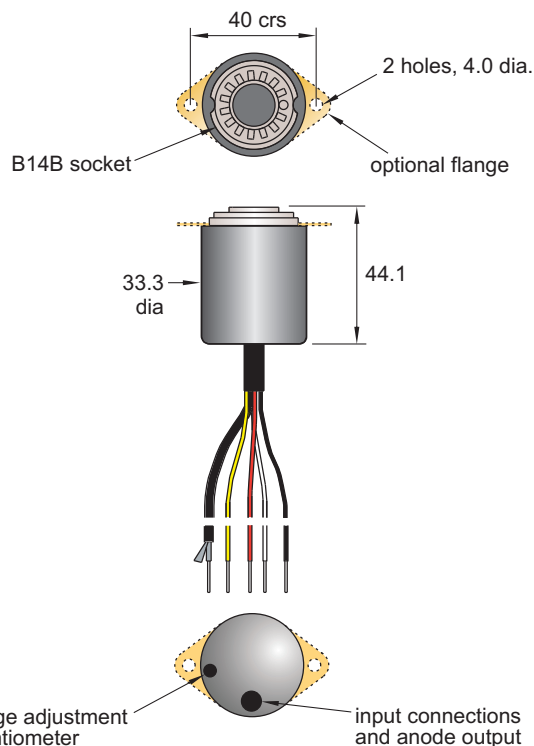

## 11 ordering information

item	ordering code
PS1807, +5 V	PS1807/5
PS1807, +5 V, flange	PS1807/5F
PS1807, +12 V	PS1807/12
PS1807, +12 V, flange	PS1807/12F

## 12 warning

High voltages generated by these products present an electrical shock hazard and appropriate precautions must be taken. They must be installed by qualified personnel and operated within the specified ratings.

The PS1807 is despatched with the internal potentiometer set to zero.

Do not operate outside the ratings limits. This may result in loss of performance or permanent damage to the PS1807. Do not exceed the ratings of the photomultiplier as this may damage the photomultiplier and the power supply.