

photomultiplier power base (negative) PS1822 data sheet

1 description

The PS1822 is a compact photomultiplier power base incorporating a negative high voltage supply. The active divider ensures low rate effect and low ripple.

It is housed in a cylindrical metal enclosure to provide electrical screening. Low voltage connections are by 500 mm long insulated leads, and the anode output is via a 500 mm long RG174U screened coaxial cable.

The dynode potentials are provided directly to the socket contacts. The anode is directly connected to the RG174U coaxial cable - there is no load resistor.

The overall operating voltage for the photomultiplier can be precisely set using any one of the three programming options shown in section 9.



Examples of the Sens-Tech's range of power bases

2 applications

The PS1822 is suitable for the following applications:

- analogue
- pulsed light
- photon counting

3 features

- compact design
- freedom from high voltage cables
- low ripple
- exceptional voltage divider stability with varying anode current
- excellent pulse height linearity
- sleep mode

4 specification

input power at $V_{\max} = -1800$ V	+5 V, 60 mA
power conversion efficiency, P_o/P_{in}	40 % for +5 V
input power at $V_{\max} = -1800$ V	+12 V, 20 mA
power conversion efficiency, P_o/P_{in}	50 % for +12 V
output voltage range	-100 V to -1800 V
line regulation	0.05 % /V
temperature coefficient	<0.02 % °C ⁻¹
warm up time to 0.3 % of final o/p	< 2 s
discharge time to <40 V with no load	< 2 s
maximum anode current, continuous	100 µA
anode ripple with 100 k //5 pF load	100 µV
weight	150 g

5 ratings

input voltage (PS1822/5)	+4.75 V to +6.0 V
input voltage (PS1822/12)	+11 V to +13 V
control voltage	0 to +1.8 V
temperature (operating)	+ 5 °C to +55 °C

6 schematic diagram

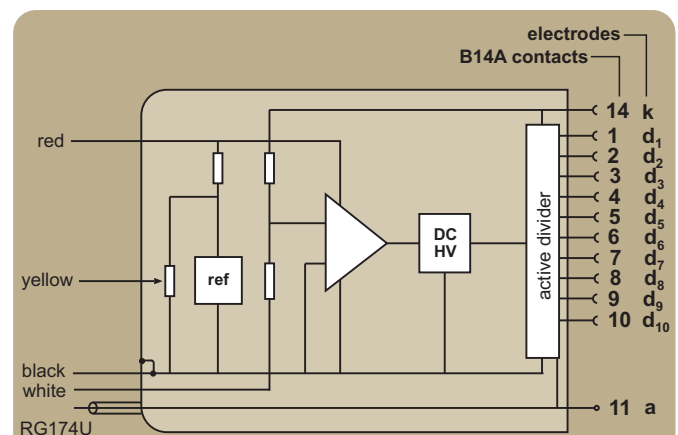

example of output voltage with 0.700 volts applied to control (white) wire

contact	electrode	voltage	contact	electrode	voltage
1	d ₁	-500	8	d ₈	-150
2	d ₂	-450	9	d ₉	-100
3	d ₃	-400	10	d ₁₀	-50
4	d ₄	-350	11	a	0 V
5	d ₅	-300	12	nc	-
6	d ₆	-250	13	nc	-
7	d ₇	-200	14	k	-700

nc - no connection

7 voltage distribution

The photomultiplier pin configuration compatible with this power base is given below.

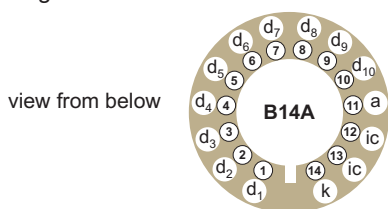

k	d ₁	d ₂	d ₉	d ₁₀	a
4V/14	V/14	V/14	V/14	

where V is the overall high voltage

8 sleep mode

The power consumption can be reduced by half to one third of its normal level by activating the sleep mode. This is done by taking the control voltage (white) to 0 V.

9 programming options

1) internal potentiometer (access from back of power supply, clockwise to increase HV)

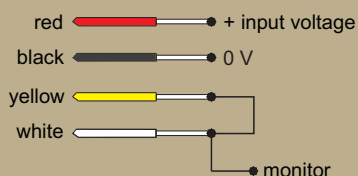

2) external potentiometer (the internal potentiometer must be set fully clockwise)

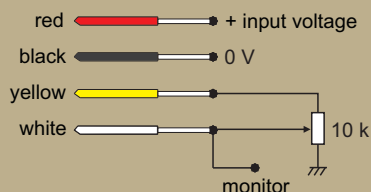

3) external voltage

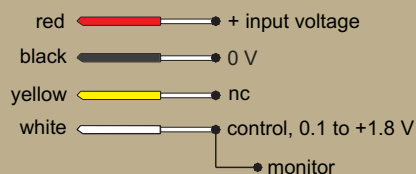

nc: no connection - isolated lead

voltage monitor: 1/1000 of the HV applied to photomultiplier

10 outline drawing (mm)

All input connections are 7/0.2 PVC covered, 0.5 m in length. The anode lead is RG174U, also 0.5 m in length.

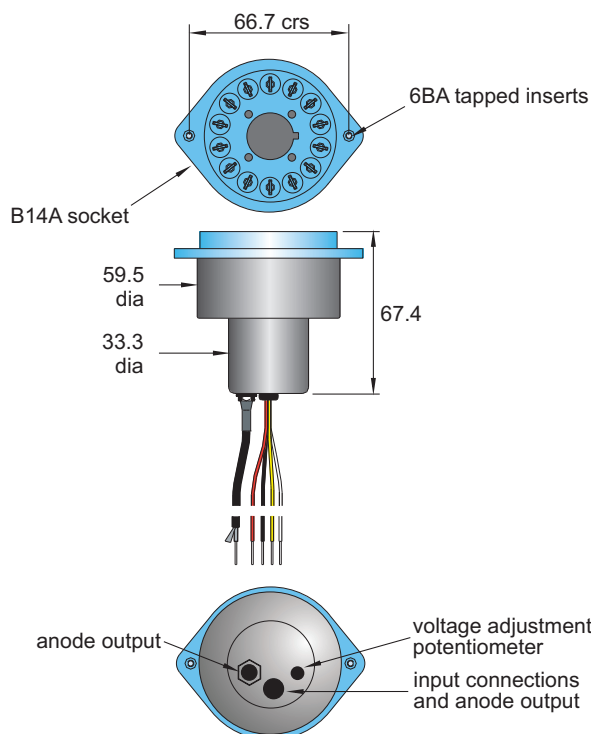

11 ordering information

item	ordering code
PS1822, +5 V	PS1822/5
PS1822, +12 V	PS1822/12

12 warning

High voltages generated by these products present an electrical shock hazard and appropriate precautions must be taken. They must be installed by qualified personnel and operated within the specified ratings.

The PS1822 is despatched with the internal potentiometer set to zero.

Do not operate outside the ratings limits. This may result in loss of performance or permanent damage to the PS1822. Do not exceed the ratings of the photomultiplier as this may damage the photomultiplier and the power supply.