

photomultiplier power base (negative) PS1823 data sheet

1 description

The PS1823 is a compact photomultiplier power base incorporating a negative high voltage supply and an active voltage divider. It is suitable for use with 10 stage, 52 mm diameter, capped photomultipliers with an overall voltage range of -100 to -1800 V.

It is housed in a cylindrical metal enclosure to provide electrical screening. Low voltage connections are by 500 mm long insulated leads, and the anode output is via a 500 mm long RG174U screened coaxial cable.

The dynode potentials are provided directly to the socket contacts. The anode is directly connected to the RG174U coaxial cable - there is no load resistor.

The overall operating voltage for the photomultiplier can be precisely set using any one of the three programming options shown in section 9.



2 applications

The PS1823 is suitable for the following applications:

- analogue
- pulsed light
- photon counting

3 features

- compact design
- freedom from high voltage cables
- low ripple
- exceptional voltage divider stability with varying anode current
- excellent pulse height linearity
- sleep mode

4 specification

input power at $V_{max} = -1800$ V	+5 V, 60 mA
power conversion efficiency, P_o/P_{in}	40 % for +5 V
input power at $V_{max} = -1800$ V	+12 V, 20 mA
power conversion efficiency, P_o/P_{in}	50 % for +12 V
output voltage range	-100 V to -1800 V
line regulation	0.05 % /V
temperature coefficient	<0.02 % °C ⁻¹
warm up time to 0.3 % of final o/p	< 2 s
discharge time to <40 V with no load	< 2 s
maximum anode current, continuous	100 μ A
anode ripple with 100 k Ω /5 pF load	100 μ V
weight	150 g

5 ratings

input voltage (PS1823/5)	+4.75 V to +6.0 V
input voltage (PS1823/12)	+12 V to +15 V
control voltage	0 to +1.8 V
temperature (operating)	+5 °C to +55 °C

6 schematic diagram

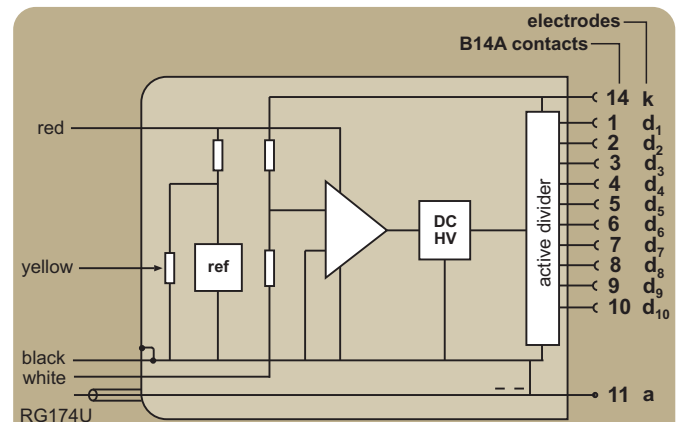

example of output voltage with 1.300 V applied to control (white) wire

contact	electrode	voltage	contact	electrode	voltage
1	d ₁	-1000	8	d ₈	-300
2	d ₂	-900	9	d ₉	-200
3	d ₃	-800	10	d ₁₀	-100
4	d ₄	-700	11	a	0 V
5	d ₅	-600	12	nc	-
6	d ₆	-500	13	nc	-
7	d ₇	-400	14	k	-1300

nc - no connection

7 voltage distribution

The photomultiplier pin configuration compatible with this power base is given below.

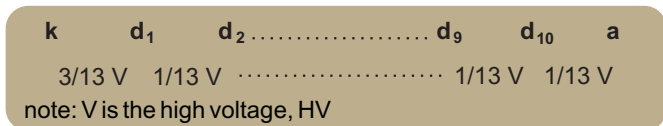
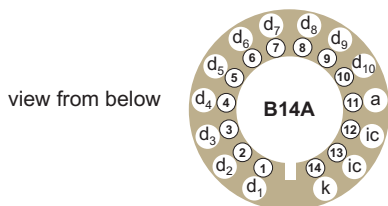

8 sleep mode

The power consumption can be reduced by half to one third of its normal level by activating the sleep mode. This is done by taking the control voltage (white) to 0 V.

9 programming options

internal potentiometer
(access from back of power supply, clockwise to increase HV)

red — + input voltage
black — 0 V
yellow —
white — monitor

red — + input voltage
black — 0 V
yellow —
white — 10 k
monitor

red — + input voltage
black — 0 V
yellow — nc
white — control, 0.1 to +1.8 V
monitor

nc: no connection - isolated lead
voltage monitor: 1/1000 of the HV applied to photomultiplier

10 outline drawing (mm)

All input connections are 7/0.2 PVC covered, 0.5 m in length. The anode lead is RG174U, also 0.5 m in length.

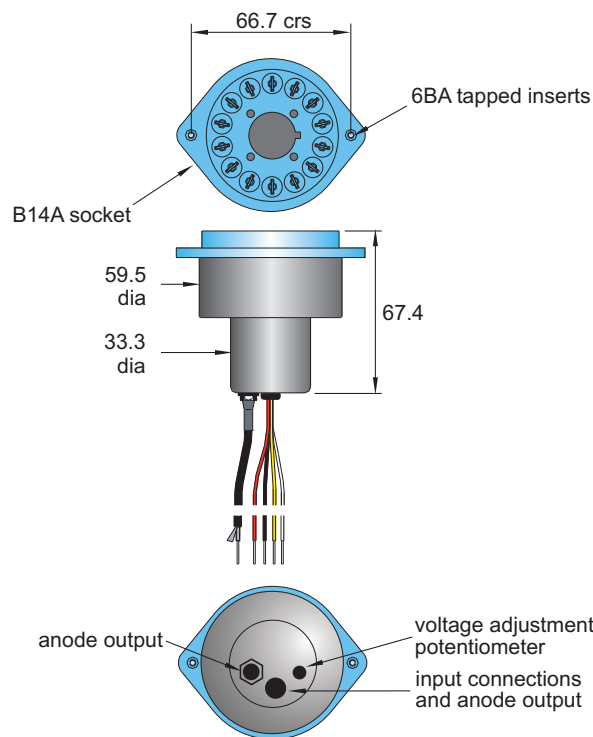

11 ordering information

item	ordering code
PS1823, +5 V	PS1823/5
PS1823, +5 V, flange	PS1823/5F

12 warning

High voltages generated by these products present an electrical shock hazard and appropriate precautions must be taken. They must be installed by qualified personnel and operated within the specified ratings.

The PS1823 is despatched with the internal potentiometer set to zero.

Do not operate outside the ratings limits. This may result in loss of performance or permanent damage to the PS1823. Do not exceed the ratings of the photomultiplier as this may damage the photomultiplier and the power supply.