

## 1 description

XDAS-HE is a modular system of boards for data acquisition in linescan systems using X-ray or Linac sources. The large dynamic range of the detector makes it possible to use high energies and pulsed sources. An XDAS-HE system consists of a set of detector head boards and signal processing boards. Each detector head board has 64 detector channels. Up to 7 signal processing boards can be used in a single system, each driving 64 detector head boards. This data sheet describes the 2.5mm pitch system but other configurations, with adapter boards, can be supplied to special order.

## 2 applications

- container inspection
- vehicle checking
- cargo inspection

## 3 features

- modular system with up to 64 detector head boards per signal processing board
- 2.5 mm detector pitch, other designs to special order
- low electronic noise
- range of scintillator types
- simultaneous data acquisition and read-out
- wide dynamic range 50pC to 350 pC
- 20 bit output
- 320  $\mu$ s minimum signal integration time
- energy up to 6MeV

## 4 XDAS-HE system

Current from the photodiodes is integrated by a microcircuit containing 64 charge sensitive amplifiers and a 20-bit A/D convertor. The microcircuit provides a serial digital output which is fed to the signal processing board using LVDS transceivers.

Operation is continuous, with one set of data being read-out whilst the next set is acquired. Dead time is less than 100ns. There is zero dead time in continuous scan mode. In triggered mode, dead-time depends on system configuration. Contact Sens-Tech for advice.

The maximum charge that can be collected per cycle depends on the choice of storage capacitors, one per channel, which are internal to the microcircuit. These can be set from 50pC to 350pC in steps of 50pC. High linearity is maintained with charge storage of 50pC to 350pC per cycle. Each detector board may be programmed with a different charge capacity.

A system is built up by daisy-chaining detector head boards to the signal processing board via a 50-way ribbon cable, which has differential data lines, as shown on **detector head block diagram, Section 11**. Four inputs are provided on the signal processing board, each of which can be connected to 16 detector head boards giving a total of 64 detector head boards for one signal processing board. There can be up to 7 signal processing boards in a system. The operation of the system is controlled by a gate array

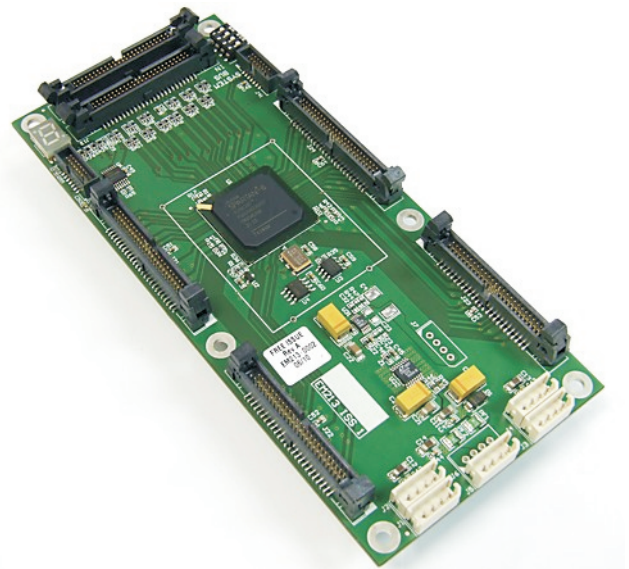
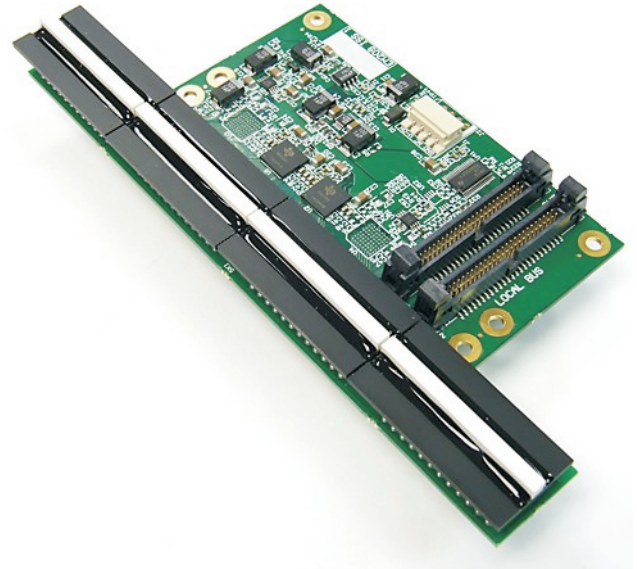

(FPGA), which provides the central intelligence for the board and the timing and control signals for system operation. See **system block diagram, Section 12**.

User settings to control integration times, sub-sampling and refresh rate, together with information on system configuration, are transmitted via an LVDS interface and stored in non-volatile RAM such that on switch-on, the system is initiated in the last mode used. The LVDS is compatible with the RS232 serial port on standard PC's using the interface converter supplied. When the USB2 or Ethernet option is chosen, the communications are made via this connection.

## 5 data interface options

Data interface to a PC is via a PCI-7300A data I/O card, USB2 module or Ethernet. The same configuration of XDAS-HE system is used for each mode, but different interface adaptors are required.

XDAS-USB2-1-V3 provides a local USB2.0 interface other types on application

## 6 data acquisition rate

This is normally determined by the speed of the A/D converter. A single detector board requires 320µs conversion time for all 64 channels. A system with a single signal processing card and the maximum number of 64 detector head boards requires 20.48ms to read out. If a faster rate is required, further signal processing cards can be added. System read-out speed can be set to 2.5, 5, 10, 20 and 40MB/s

## 7 general specification

integration time (single sample)	320µs to 1s
electronic noise*	
no detector 50pC	10ppm
no detector 350pC	6ppm
with detector 50pC	150ppm
with detector 350pC	25ppm
integral linearity	<0.1 %
maximum read-out rate	40 MB/s
A/D conversion	20 bit
data output	3 bytes per channel
detector pitch	2.5mm
detector active area	2.14mm x 2.5mm
maximum number of signal processing boards	448
maximum number of channels	28672

\*Cd, 1nF, integration time 333µs

## 8 environmental specification

operating temperature	+ 5 to + 35 °C
storage temperature	-40 to +70 °C
humidity (non-condensing)	
operating	30 °C 93 %
non-operating	40 °C 93 %

## 9 evaluation system

An evaluation system can be supplied, consisting of a detector head board, detectors, signal processing board, USB output and evaluation software. This is mounted in a test box to provide electrical and radiation screening.

The software is available on a CD and can be loaded on to a PC (Pentium 4 or higher) to provide the basic functionality of the system. A serial port is required for PCI7300A or frame grabber interfaces. A high speed USB2.0 port is required for XDAS-USB2-1-V3 interface. The software enables integration time and number of sub-samples to be set and single lines of data to be acquired.

Data is acquired into a spreadsheet and can be displayed in graphical form. Gain and offset correction can be applied via the software.

## 10 ordering information

part number	description
XDAS-DH-90	detector head board 2.5mm pitch, 128 channels, no detectors
XDAS-DH-91	detector head board 2.5mm pitch, 128 channels, Gadox detectors
XDAS-DH-92	detector head board 2.5mm pitch, 128 channels, CsI detectors
XDAS-DH-93	detector head board 2.5mm pitch, 128 channels, CdWO4 detectors
XDAS-SP3-09	signal processing board
XDAS - SOFTWARE	evaluation software and SDK
XDAS-USB2-1-V3	control and interface module for local USB2, up to 5 metres to CPU

### 11 detector head block diagram

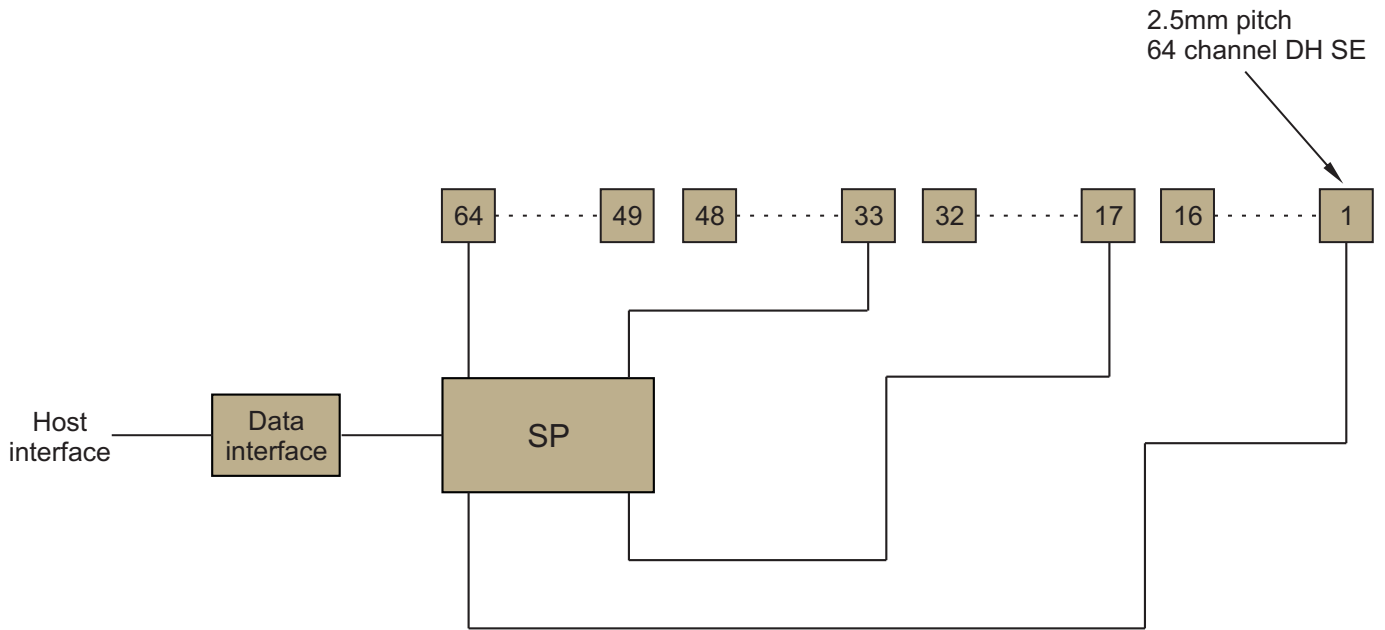

### 12 system block diagram

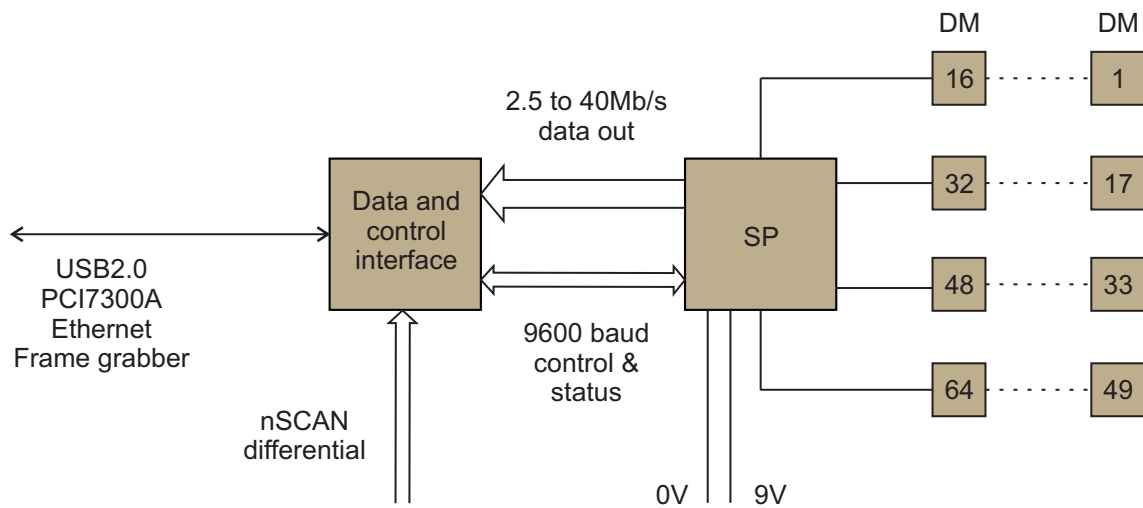

**XDAS-DH-90 single energy board**

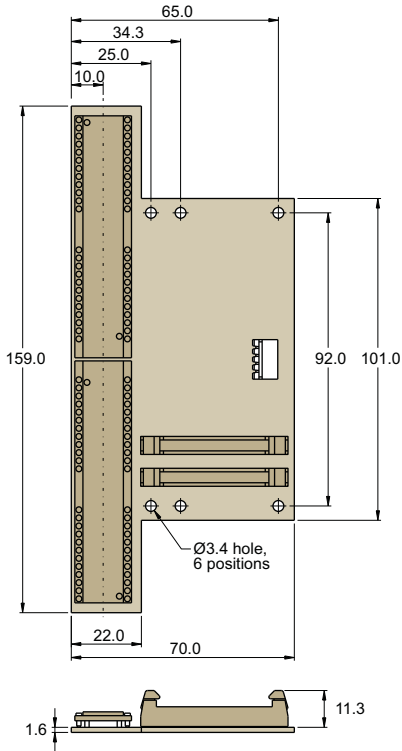

**XDAS-SP3-09 signal processing board**

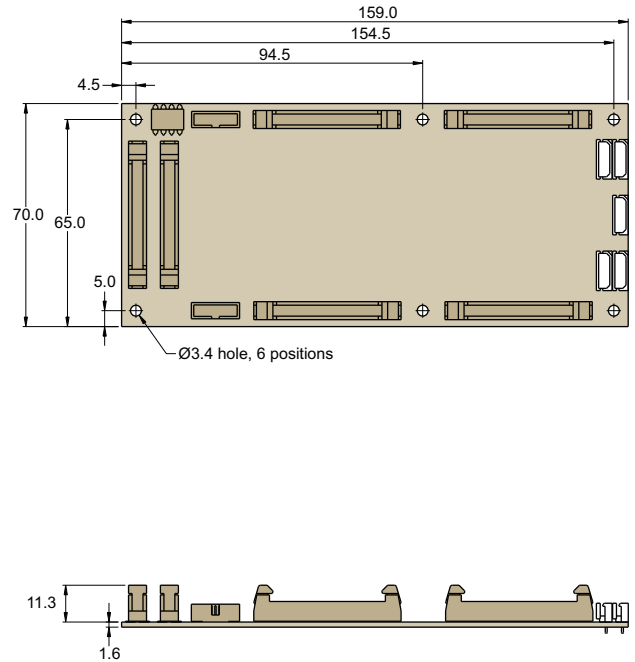

14 detector outline drawings (mm)

**2.5 mm pitch Gadox**

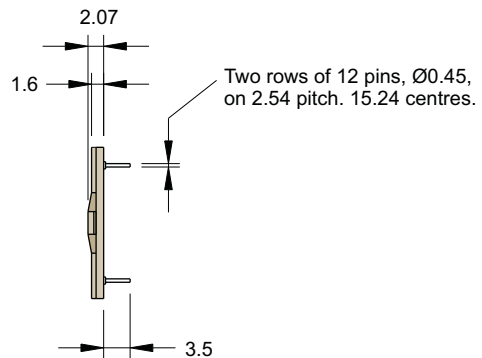
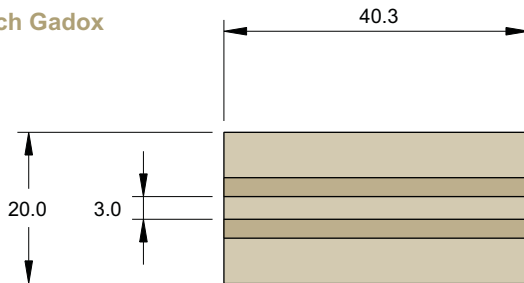

**2.5 mm pitch CsI**

