

X-ray data acquisition

XDAS-V2 0.4mm single energy

1 description

XDAS-V2 is a modular system of boards for use in X-ray linescan and CT Systems. It consists of a set of detector head boards and signal processing boards. Each detector head board has 128 detector channels. Up to 7 signal processing boards can be used in a system, each controlling up to 24 detector head boards. Several different detector pitches are available. This data sheet describes the 0.4mm pitch, single energy system. A dual energy system can be configured by mounting two boards one above the other.

2 applications

food inspection and drink
pharmaceutical quality control
thickness measurement
casting inspection

3 features

modular system with up to 24 detector head boards per single signal processing board
0.4 mm detector pitch
x-ray energy 30keV to 120keV
low electronic noise
range of scintillator types
simultaneous data acquisition and read-out
wide dynamic range 3pC to 60 pC
16 bit output
60 μ s minimum signal integration time

4 XDAS-V2 system

Current from the photodiodes is integrated by a microcircuit containing 128 charge sensitive amplifiers. See **detector head block diagram, section 11**. Correlated double sampling is used to minimise common mode noise. The microcircuit provides a multiplexed serial analogue output to the signal processing board where data is converted into 14-bit format. Operation is continuous, with one set of data being read-out whilst the next set is acquired. Dead time is less than 1 μ s.

The dynamic range of the system is determined by the storage capacitors within the ASIC. These can be set to 2pF or 10pF, providing charge storage of 3pC or 15pC. If this is insufficient, a multiple sampling facility is provided in the signal processing board. This enables 2 or 4 samples to be averaged and the result stored a 16-bit image store. This provides a maximum dynamic range of 60pC. All 16 bits of data are output.

The operation of the system is controlled by a gate array which provides the central intelligence for the signal processing board and the timing and control signals for system operation. See **signal processing block diagram, section 12**. Control settings are transmitted to the board via an RS485 interface and stored in non-volatile RAM such that on switch-on, the system is initiated in the last mode used. The RS485 is compatible with the RS232 serial port on standard PC's using the interface converter supplied. When the USB2 interface option is chosen, the communications are made via this connection.



A system is built up by daisy-chaining detector head boards to the signal processing board via a 40-way ribbon cable, which has differential data lines, as shown on **the system block diagram, section 13**. Two inputs are provided on the signal processing board, each of which can be connected to 12 detector head boards giving a total of 24. The system bus data rate is 2.5 to 20MB/s.

5 data interface options

The signal processing board is connected to the processor via a Data Control and Interface Module. Two types are available, providing the following interfaces.

1. XDAS-DATA3 provides a SCSI output with a cable up to 50M connecting to:
 - USB2.0 converter box XDAS-USB2
 - PCI7300 card, via an XDAS-485A-TTL
 - Frame Grabber, via an XDAS-485A-DFG
 - Ethernet, via an XDAS-ETHERNET-L
2. XDAS-USB2-1 provides a local USB2.0 output, limiting the distance to the processor to 5M.

6 data acquisition rate

This is normally determined by the speed of the A/D converter. The standard is 2.5MHz and this will convert a single detector head board in 51.2µs. A 10 board system can be read out in 512µs. The A/D converter normally limits the integration time that can be used. If faster integration and read-out is required, further signal processing boards can be added. For large systems, the speed of the system bus will be the determining factor but when set for 20MHz a 1.25ms sample time can be achieved for a system of 24 boards.

7 general specification

integration time (single sample)	60µs to 50ms
sub-samples	4
integration time multiple samples	200ms (max)
signal-to-noise (electronic)*	
2pF mode	20000:1
10pF mode	34000:1
cross talk (channel to channel)	<0.1% for 10pC
maximum read-out rate	20MB/s
A/D conversion	14 bit
data output	16 bit
detector pitch	0.4mm
detector active area	0.3mm x 0.6mm
maximum number of signal processing boards	7
maximum number of data head boards	168
maximum number of channels	21504

*500µs integration time, 4 sub samples

8 environmental specification

operating temperature	+ 5 to + 35°C
storage temperature	-40 to +70°C
humidity (non-condensing)	
operating	30°C 93%
non-operating	40°C 93%

9 evaluation system

An evaluation system is available, consisting of a detector head board, detectors, signal processing board, USB output and evaluation software.

This is mounted in a test box (LINX type, see data sheet) to provide electrical and radiation screening.

The software is available on a CD and can be loaded on to a PC (Pentium 4 or higher) to provide the basic functionality of the system. A serial port is required for PCI7300A or frame grabber interfaces. A high speed USB2.0 port is required for XDAS-USB2 interface. The software enables integration time and number of sub-samples to be set and single lines of data to be acquired.

Data is acquired into a spreadsheet and can be displayed in graphical form. Gain and offset correction can be applied via the software.

10 ordering information

part number	description
XDAS-DH2-61	Detector Head board 0.4mm pitch, 128 channels, Gadox
XDAS-DH2-64	Detector Head board 0.4mm pitch, 128 channels, bare silicon
XDAS-SP2-01	Signal Processing Board
XDAS-SOFTWARE	evaluation software and SDK
XDAS-USB2-1	control and interface module for local USB2 , up to 5 metres to the processor
XDAS-DATA3	control and interface module for remote applications with 50-way SCSI cable
XDAS-USB2	adaptor module SCSI to USB2, up to 50 metres to the processor
XDAS-485A-TTL	adaptor board for PCI7300A card
XDAS-485A-DFG	adaptor board for frame grabber card check compatibility for type
XDAS-CONV8-16	converts output from 8 to 16 bit format to be compatible with frame grabber

11 detector head block diagram

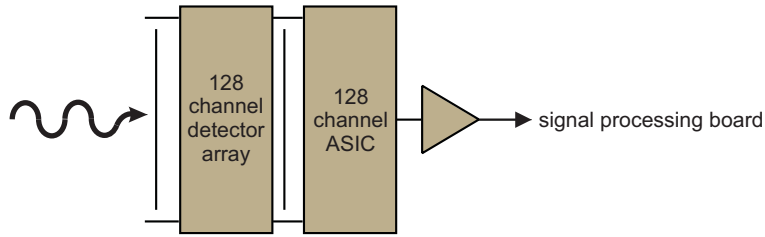

12 signal processing block diagram

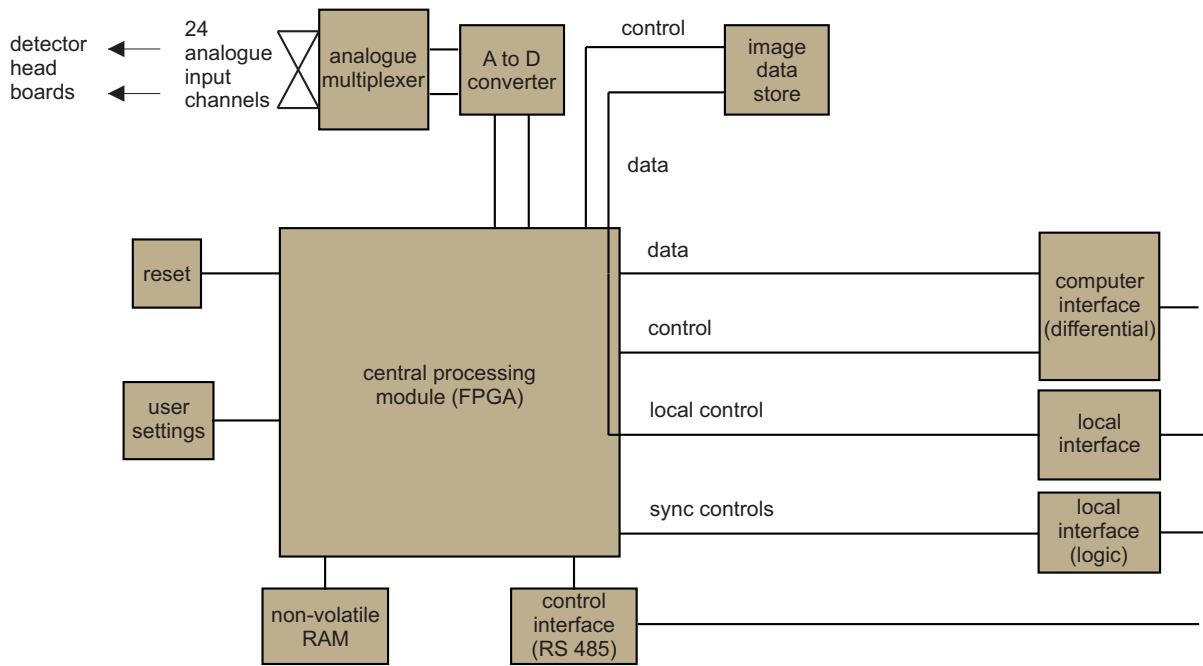

13 system block diagram

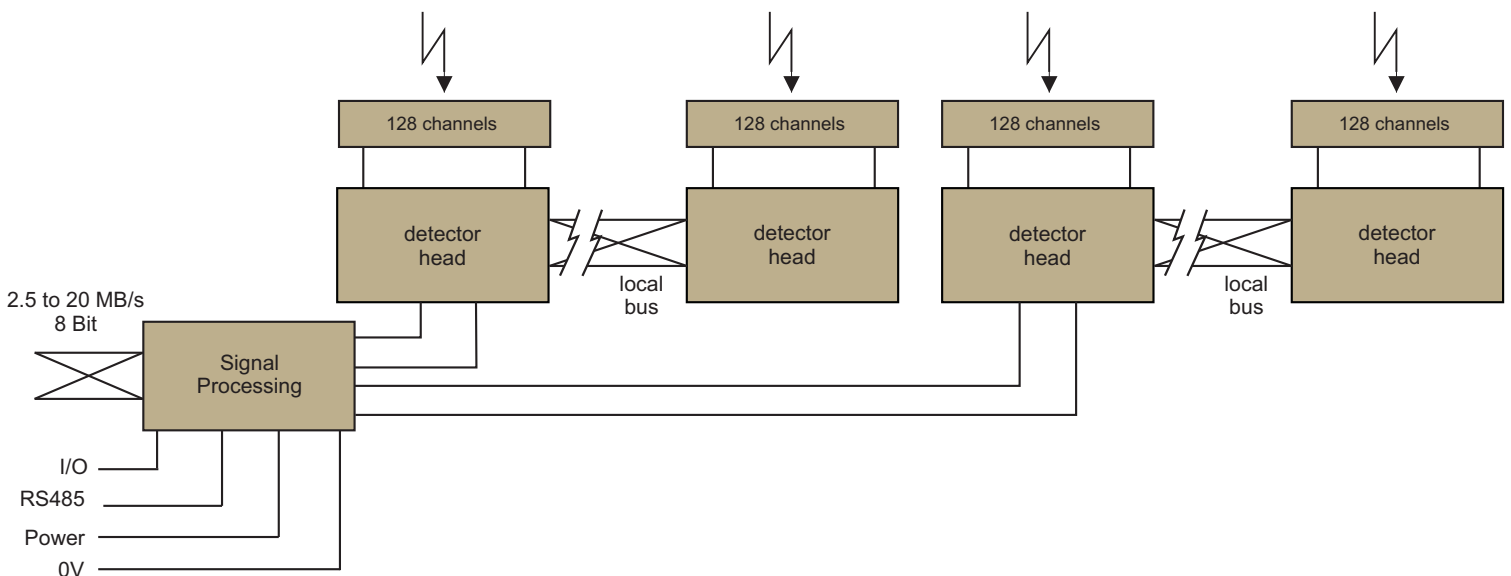

**XDAS-DH2-64 single energy board
bare silicon**

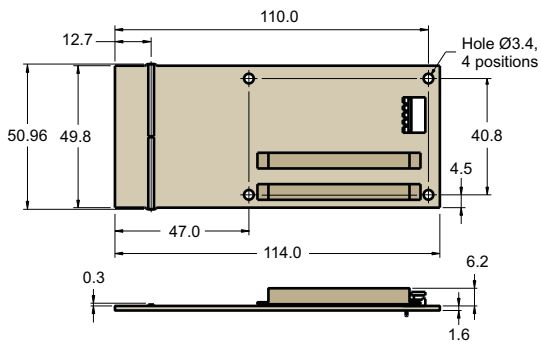

XDAS-SP2-01 signal processing board

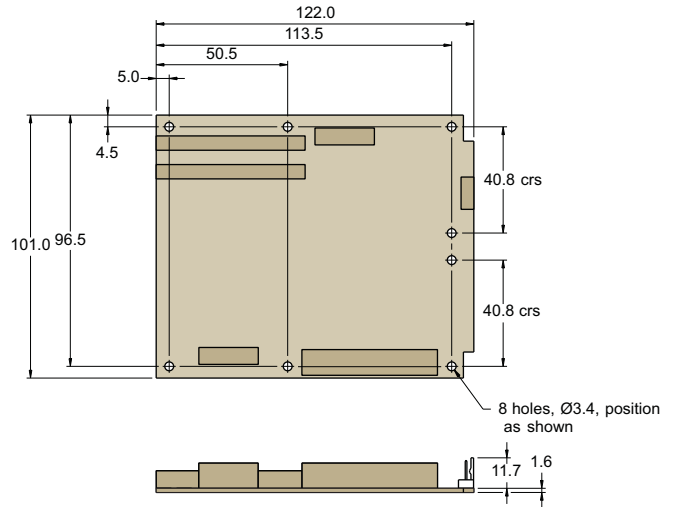

**XDAS-DH2-61 single energy board
with GADOX**

