

X-ray data acquisition dual energy XDAS-V2 1.6mm pitch



1 description

XDAS-V2 is a modular system of boards for data acquisition in X-ray linescan and CT systems. It consists of a set of detector head boards and signal processing boards. Each detector head board has 128 detector channels. Up to 7 signal processing boards can be used in a system, each controlling up to 24 detector head boards. Several different detector pitches are available. This data sheet describes the 1.6mm pitch, dual energy system. 64 low energy detectors are mounted on the upper side of the board (closest to X-ray source) and 64 high energy detectors on the underside. A copper filter can be fitted in between. The thickness of the filter depends on the X-ray energy.

2 applications

- security inspection
- waste sorting
- mineral sorting
- fat/lean measurement

3 features

- modular system with up to 24 detector head boards per single signal processing board
- 1.6 mm detector pitch
- X-ray energy range 30keV to 250keV
- low electronic noise
- range of scintillator types for single and dual energy
- simultaneous data acquisition and read-out
- wide dynamic range 3pC to 60pC
- 16 bit output
- 100 μ s minimum signal integration time

4 XDAS-V2 system

Current from the photodiodes is integrated by a microcircuit containing 128 charge sensitive amplifiers. See **detector head block diagram, section 11**. Correlated double sampling is used to minimise common mode noise. The microcircuit provides a multiplexed serial analogue output to the signal processing board where data is converted into 14-bit format. Operation is continuous, with one set of data being read-out whilst the next set is acquired. Dead time is less than 1 μ s.

The dynamic range of the system is determined by the storage capacitors within the ASIC. These can be set to 2pF or 10pF, providing charge storage of 3pC or 15pC. If this is insufficient, a multiple sampling facility is provided in the signal processing board. This enables 2 or 4 samples to be averaged and the result stored a 16-bit image store. This provides a maximum dynamic range of 60pC. All 16 bits of data are output.

The operation of the system is controlled by a gate array which provides the central intelligence for the signal processing board and the timing and control signals for system operation. See **signal processing block diagram, section 12**. Control settings are transmitted to the board via an RS485 interface and stored in non-volatile RAM such that

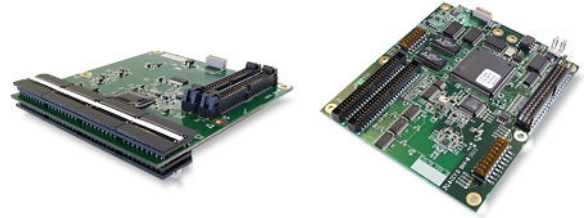

on switch-on, the system is initiated in the last mode used. The RS485 is compatible with the RS232 serial port on standard PC's using the interface converter supplied. When the USB2 interface option is chosen, the communications are made via this connection.

A system is built up by daisy-chaining detector head boards to the signal processing board via a 50-way ribbon cable, which has differential data lines, as shown on the **system block diagram, section 13**. Two inputs are provided on the signal processing board, each of which can be connected to 12 detector head boards giving a total of 24. The system bus data rate is 2.5 to 20MB/s.

5 XDAS-V2 system

The signal processing board is connected to the processor via a Data Control and Interface Module. Two types are available, providing the following interfaces.

1. XDAS-DATA3 provides a SCSI output with a cable up to 50M connecting to:
 - USB2.0 converter box XDAS-USB2
 - PCI7300 card, via an XDAS-485A-TTL
 - Frame Grabber, via an XDAS-485A-DFG
2. XDAS-USB2-1 provides a local USB2.0 output, limiting the distance to the processor to 5 metres.

6 data acquisition rate

This is normally determined by the speed of the A/D converter. The standard is 2.5MHz and this will convert a single detector head board in 51.2 μ s. A 10 board system can be read out in 512 μ s. The A/D converter normally limits the integration time that can be used. If faster integration and read-out is required, further signal processing boards can be added. For large systems, the speed of the system bus will be the determining factor but when set for 20MHz a 1.25ms sample time can be achieved for a system of 24 boards.

7 general specification

integration time (single sample)	100µs to 50ms
sub-samples	4
integration time (multiple samples)	200ms (max)
signal-to-noise (electronic)*	
2pF mode	20000:1
10pF mode	34000:1
cross talk (channel to channel)	<0.1% over 10pC
maximum read-out rate	20MB/s
A/D conversion	14 bit
data output	16 bit
detector pitch	1.6 mm
detector active area	1.175mm x 2.0mm
maximum number of signal processing boards	7
maximum number of channels	10752

*500µs integration time, 4 sub samples

8 environmental specification

operating temperature	+ 5 to + 35°C
storage temperature	-40 to +70°C
humidity (non-condensing)	
operating	30°C 93%
non-operating	40°C 93%

9 evaluation system

An evaluation system is available, consisting of a detector head board, detectors, signal processing board, USB output and evaluation software.

This is mounted in a test box (LINX type, see data sheet) to provide electrical and radiation screening.

The software is available on a CD and can be loaded on to a PC (Pentium 4 or higher) to provide the basic functionality of the system. The software enables integration time and number of sub-samples to be set and single lines of data to be acquired.

Data is acquired into a spreadsheet and can be displayed in graphical form. Gain and offset correction can be applied via the software.

10 ordering information

part number	description
XDAS-DH2-01	Detector Head board 1.6mm pitch, 128 channels, no detectors
XDAS-DH2-02	Detector Head board 1.6mm pitch, 64 dual energy channels Gadox and CsI
XDAS-DH2-03	Detector Head board 1.6mm pitch, 64 channels, Gadox and CdWO ₄
XDAS-SP2-01	Signal Processing Board
XDAS-SOFTWARE	evaluation software and SDK
XDAS-USB2-1	control and interface module for local USB2 , up to 5 metres to the processor
XDAS-DATA3	control and interface module for remote applications with 50-way SCSI cable
XDAS-USB2	adaptor module SCSI to USB2, up to 50 metres to the processor
XDAS-485A-TTL	adaptor board for PCI7300A card
XDAS-485A-DFG	adaptor board for frame grabber card check compatibility for type
XDAS-CONV8-16	converts output from 8 to 16 bit format to be compatible with frame grabber

11 detector head block diagram

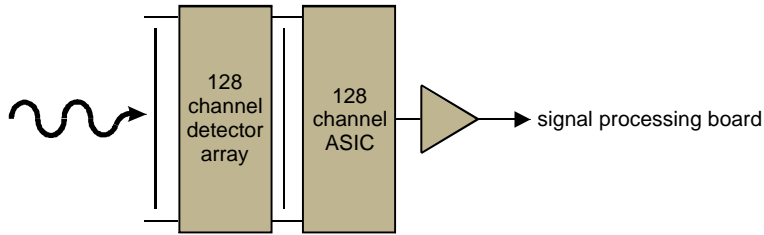

12 signal processing block diagram

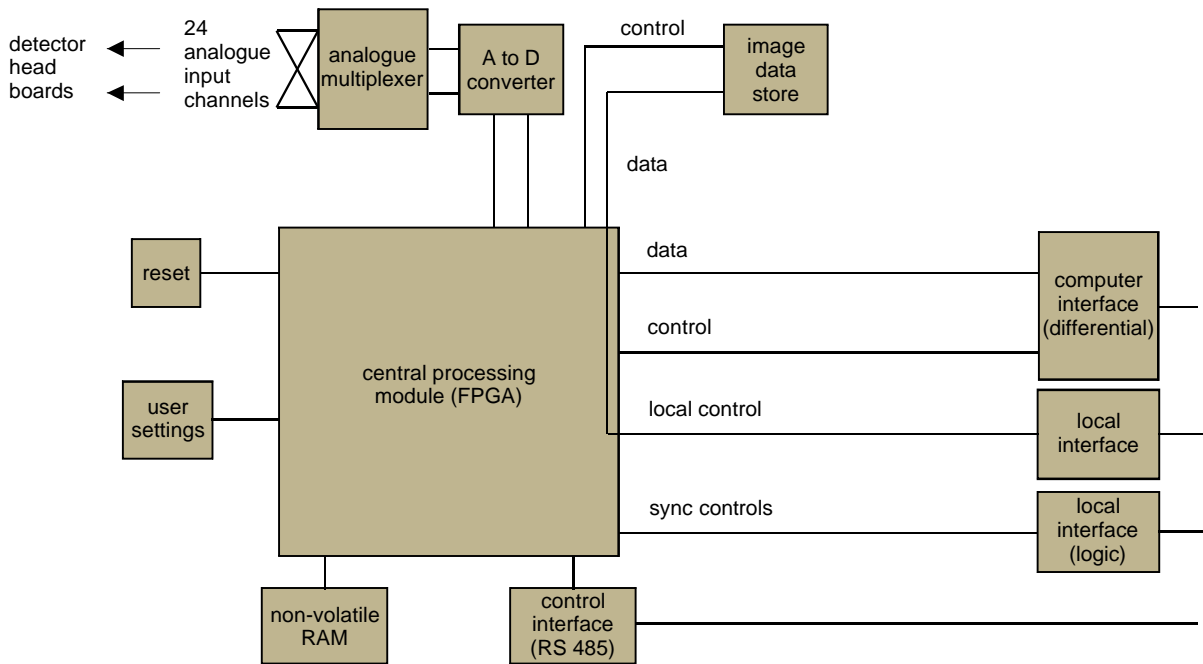

13 system block diagram

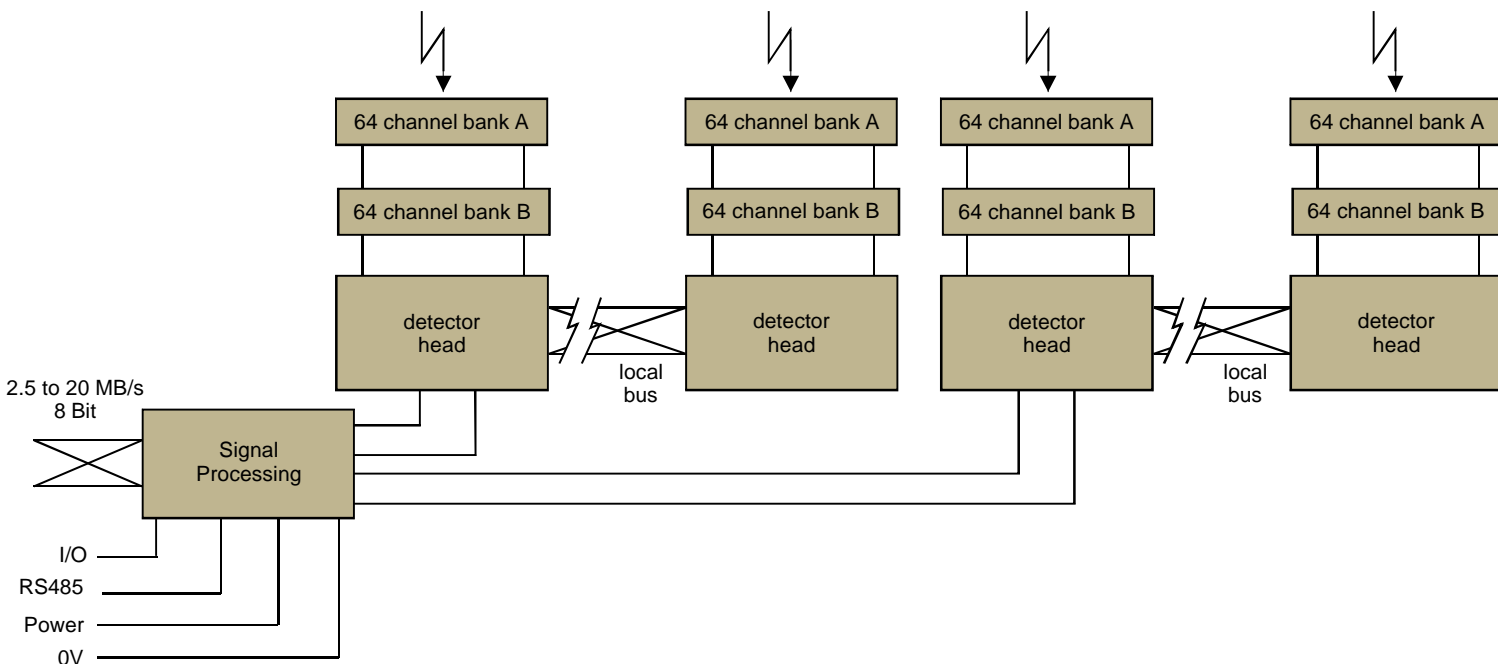

XDAS-DH2-01 dual energy board

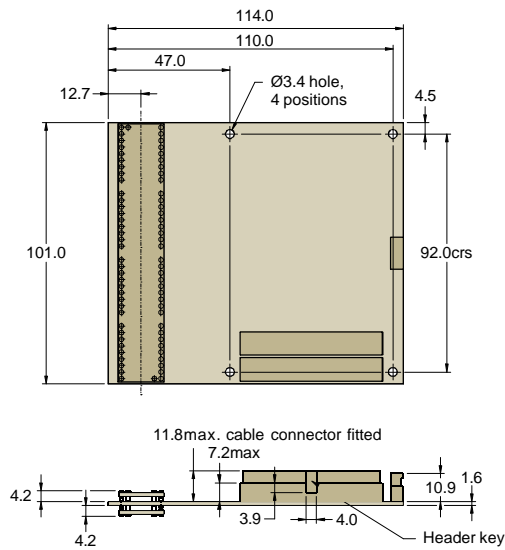

XDAS-SP2-01 signal processing board

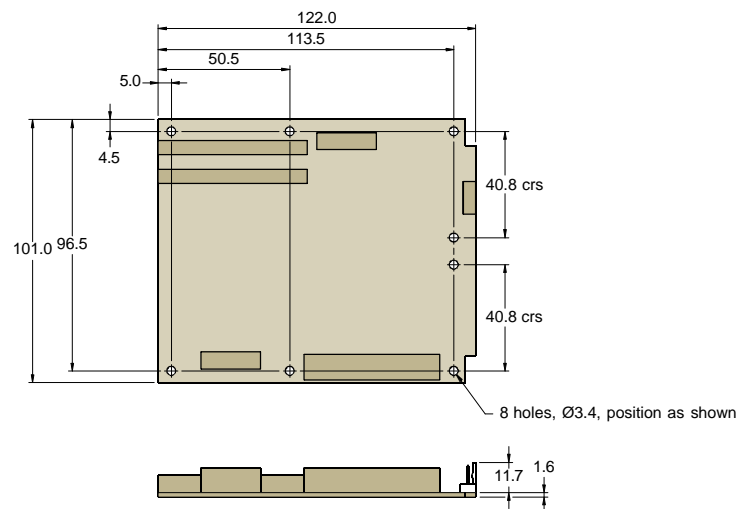

* to obtain height of detector above board, add detector socket height to detector height (excluding pins)

15 detector outline drawings (mm)

1.6 mm pitch CsI

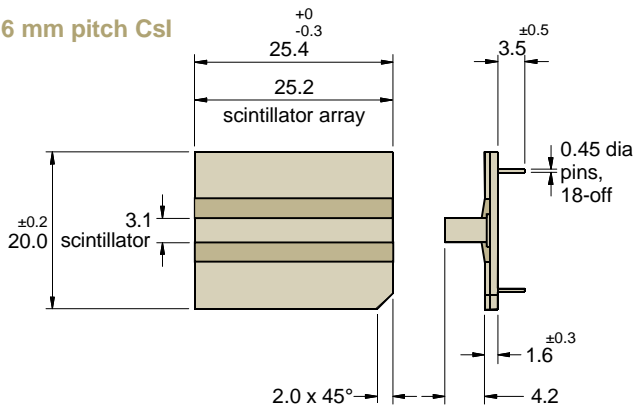

1.6 mm pitch phosphor screen

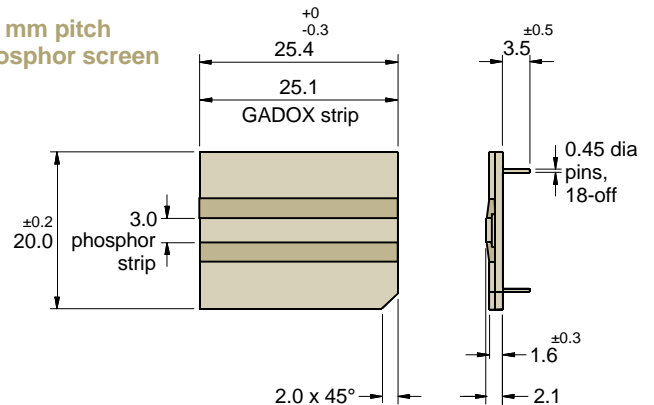

1.6 mm pitch CdWO₄

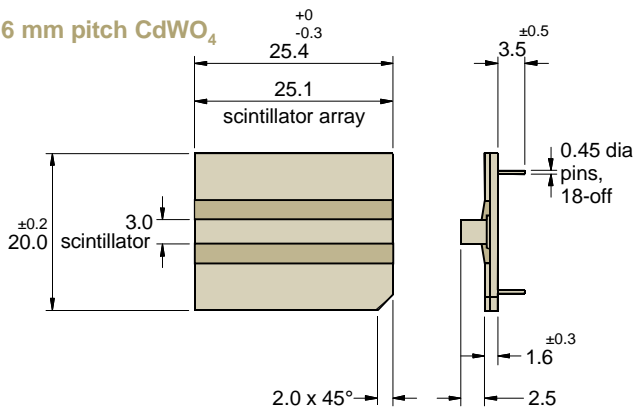

1.6 mm pitch silicon

