

PS1800N DATA SHEET

PHOTOMULTIPLIER POWER BASE (NEGATIVE)



SENS - TECH

DESCRIPTION

The PS1800N is a compact photomultiplier power base, operating at negative high voltage. The CW principle of operation provides the lowest power consumption within our range of power bases. This is particularly relevant to battery operated equipment. It is suitable for use with 11 stage, 30 mm diameter, photomultipliers with an overall voltage range of -300 to -1800 V. It is available in two versions: the PS1800N/5 operates from a +5 V supply, the PS1800N/12 requires +12 V.

It is housed in a cylindrical metal enclosure to provide electrical screening. Low voltage connections are by 450 mm long insulated leads, and the anode output is via a 450 mm long RG174U screened coaxial cable. The dynode potentials are provided directly to the socket contacts.

The overall operating voltage for the photomultiplier can be set precisely using any one of the three programming options **shown in the programming options section**.

APPLICATIONS

The PS1800N is suitable for the following applications:

- Pulsed light
- Photon counting



EXAMPLES OF THE SENS-TECH'S RANGE OF POWER BASES

FEATURES

- Extremely low power consumption
- Compact design
- No high voltage cables
- Low ripple
- Exceptional voltage divider stability with varying anode current
- Excellent pulse height linearity
- Sleep mode
- Reverse supply protected

PS1800N DATA SHEET

PHOTOMULTIPLIER POWER BASE (NEGATIVE)



SENS - TECH

SPECIFICATION

OUTPUT VOLTAGE RANGE -300 V to -1800 V	WARM UP TIME TO 0.3 % OF FINAL O/P < 1 s
ANODE CURRENT AT 1800 V MAX 200 μ A	DISCHARGE TIME TO <40 V WITH NO LOAD < 15 s
INPUT CURRENT, FULL LOAD (PS1800N/5) <36 mA	INPUT CURRENT, FULL LOAD (PS1800N/12) <15 mA
INPUT CURRENT, IDLING (PS1800N/5) <26 mA	INPUT CURRENT, IDLING (PS1800N/12) <11 mA
LOAD REGULATION (TYPICAL) 0.017% (0-100%)	LINE REGULATION (TYPICAL) 0.001 % V^{-1}
EXTERNAL VOLTAGE CONTROL 0.3 V to 1.8 V (0-100%)	REFERENCE VOLTS OUT (BLUE WIRE) 2.5V \pm 0.4%
TEMPERATURE COEFFICIENT (TYPICAL) 5 ppm $^{\circ}C^{-1}$	ANODE RIPPLE WITH 10 KΩ / 20 PF, 1 KV 4 mV pp / 0.3 mV p-p (nulled)
WEIGHT 80g	

RATINGS

INPUT VOLTAGE (PS1800N/5)+4.75 V to +8 V	TEMPERATURE (OPERATING) + 5 $^{\circ}C$ to +55 $^{\circ}C$
INPUT VOLTAGE (PS1800N/12) +11 V to +15 V	REFERENECE OUT LOAD 1mA
CONTROL VOLTAGE 0 to +1.8 V	

PS1800N DATA SHEET

PHOTOMULTIPLIER POWER BASE (NEGATIVE)



SENS - TECH

SCHEMATIC DIAGRAM

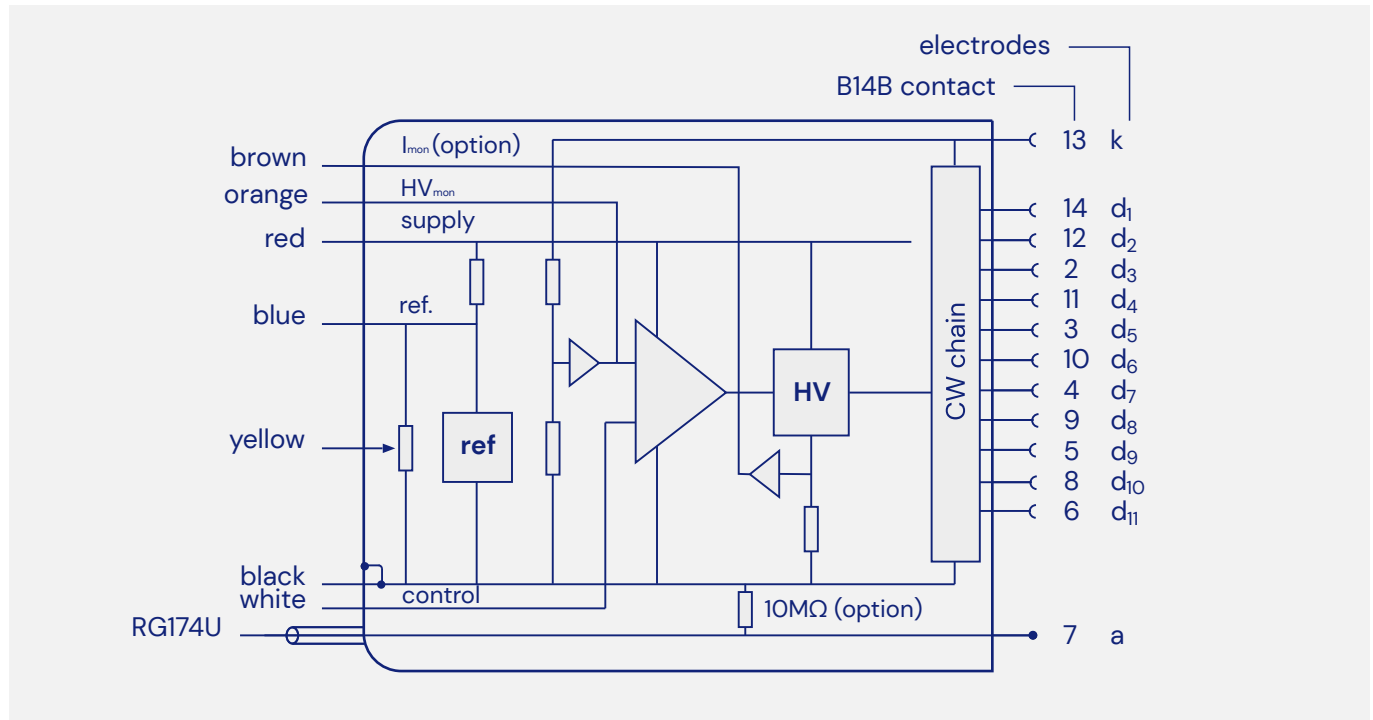

Example of output voltage with 1.300 volts applied to control (white) wire

CONTACT	ELECTRODE	VOLTAGE	CONTACT	ELECTRODE	VOLTAGE
1	nc	-	8	d ₁₀	-200
2	d ₃	-900	9	d ₈	-400
3	d ₅	-700	10	d ₆	-600
4	d ₇	-500	11	d ₄	-800
5	d ₉	-300	12	d ₂	-1000
6	d ₁₁	-100	13	k	-1300
7	a	floating	14	d ₁	-1100

PS1800N DATA SHEET



PHOTOMULTIPLIER POWER BASE (NEGATIVE)

SENS - TECH

VOLTAGE DISTRIBUTION

The photomultiplier pin configuration compatible with this power base is given below. Note that an anode load resistor is not included, but a 10MΩ safety resistor to ground can be provided as an option.

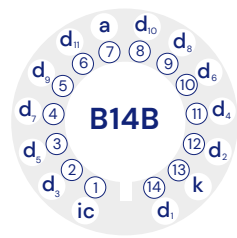

view from below

'ic' indicates an internal connection

k	d ₁	d ₂	d ₁₀	d ₁₁	a
2/13 V	1/13 V	1/13 V	1/13 V	
note: V is the high voltage, HV					

SLEEP MODE

The power consumption can be reduced by setting the HV to zero. This is done by taking the control voltage (white) to 0 V.

PROGRAMMING OPTIONS

Internal potentiometer (access from back of power supply, clockwise to increase HV)

- red + input voltage
- black 0 V
- blue nc
- yellow
- white
- orange HV monitor
- brown HV supply current monitor (option)

External potentiometer

- red + input voltage
- black 0 V
- blue
- yellow nc
- white
- orange HV monitor
- brown HV supply current monitor (option)

External voltage

- red + input voltage
- black 0 V
- blue nc
- yellow nc
- white control, 0.3 V to +1.8 V
- orange HV monitor
- brown HV supply current monitor (option)

nc: no connection – isolated lead

Voltage monitor: 1/1000 of the HV applied to photomultiplier

PS1800N DATA SHEET

PHOTOMULTIPLIER POWER BASE (NEGATIVE)



SENS - TECH

OUTLINE DRAWING MM

All input connections are 7/0.2 PVC covered, 0.45m in length. The anode lead is RG174U, also 0.45m in length.

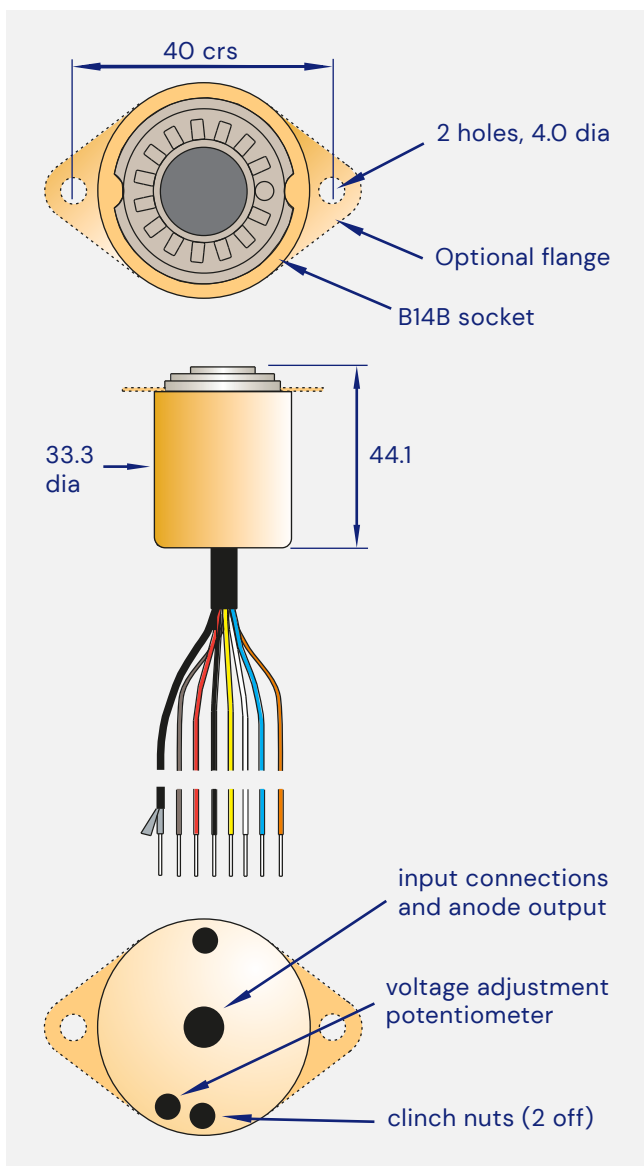

ORDERING INFORMATION

ITEM	ORDERING CODE
PS1800N, +5 V	PS1800N/5
PS1800N, +5 V, flange	PS1800N/5F
PS1800N, +12V	PS1800N/12
PS1800N, +12V, flange	PS1800N/12F

WARNING

High voltages generated by these products present an electrical shock hazard and appropriate precautions must be taken. They must be installed by qualified personnel and operated within the specified ratings.

The PS1800N is despatched with the internal potentiometer set to zero.

Do not operate outside the ratings limits. This may result in loss of performance or permanent damage to the PS1800N. Do not exceed the ratings of the photomultiplier as this may damage the photomultiplier and the power supply.