

DESCRIPTION

The PS1809 is a compact photomultiplier power base, operating at negative high voltage. The CW principle of operation provides the lowest power consumption within our range of power bases. This is particularly relevant to battery operated equipment. It is suitable for use with 10 stage, 52 mm diameter, photomultipliers with an overall voltage range of -300 to -1800 V. It is available in two versions: the PS1809/5 operates from a +5 V supply and the PS1809/12 requires +12 V.

It is housed in a cylindrical metal enclosure to provide electrical screening. Low voltage connections are by 450 mm long insulated leads, and the anode output is via a 450 mm long RG174U screened coaxial cable. The dynode potentials are provided directly to the socket contacts.

The overall operating voltage for the photomultiplier can be precisely set using any one of the three programming options **shown in the programming options section**.

APPLICATIONS

The PS1809 is suitable for the following applications:

- Pulsed light
- Photon counting



FEATURES

- Extremely low power consumption
- Compact design
- Freedom from high voltage cables
- Low ripple
- Exceptional voltage divider stability with varying anode current
- Excellent pulse height linearity
- Sleep mode

PS1809 DATA SHEET

PHOTOMULTIPLIER POWER BASE (NEGATIVE)



SENS - TECH

SPECIFICATION

OUTPUT VOLTAGE RANGE -300 V to -1800 V	WARM UP TIME TO 0.3 % OF FINAL O/P < 10 s
ANODE CURRENT AT 1800 V 200 μ A	DISCHARGE TIME TO <40 V WITH NO LOAD < 60 s
INPUT CURRENT, FULL LOAD (PS1809/5) <25 mA	INPUT CURRENT, IDLING (PS1809/5) <20 mA
INPUT CURRENT, FULL LOAD (PS1809/12) <10 mA	INPUT CURRENT, IDLING (PS1809/12) <7 mA
LOAD REGULATION 0.005% (0-100%)	ANODE RIPPLE WITH 10 KΩ / 20 PF 1KV <5 mV p-p
LINE REGULATION 0.005 % V ⁻¹	EXTERNAL VOLTAGE CONTROL 0.3 V - 1.8 V (0-100%)
TEMPERATURE COEFFICIENT <0.03 % °C ⁻¹	WEIGHT 80g

RATINGS

INPUT VOLTAGE (PS1809/5) +5 V to +8 V
INPUT VOLTAGE (PS1809/12) +12 V to +15 V
CONTROL VOLTAGE 0 to +1.6 V
TEMPERATURE (OPERATING) + 5 °C to +55 °C



PS1809 DATA SHEET

PHOTOMULTIPLIER POWER BASE (NEGATIVE)



SENS - TECH

SCHEMATIC DIAGRAM

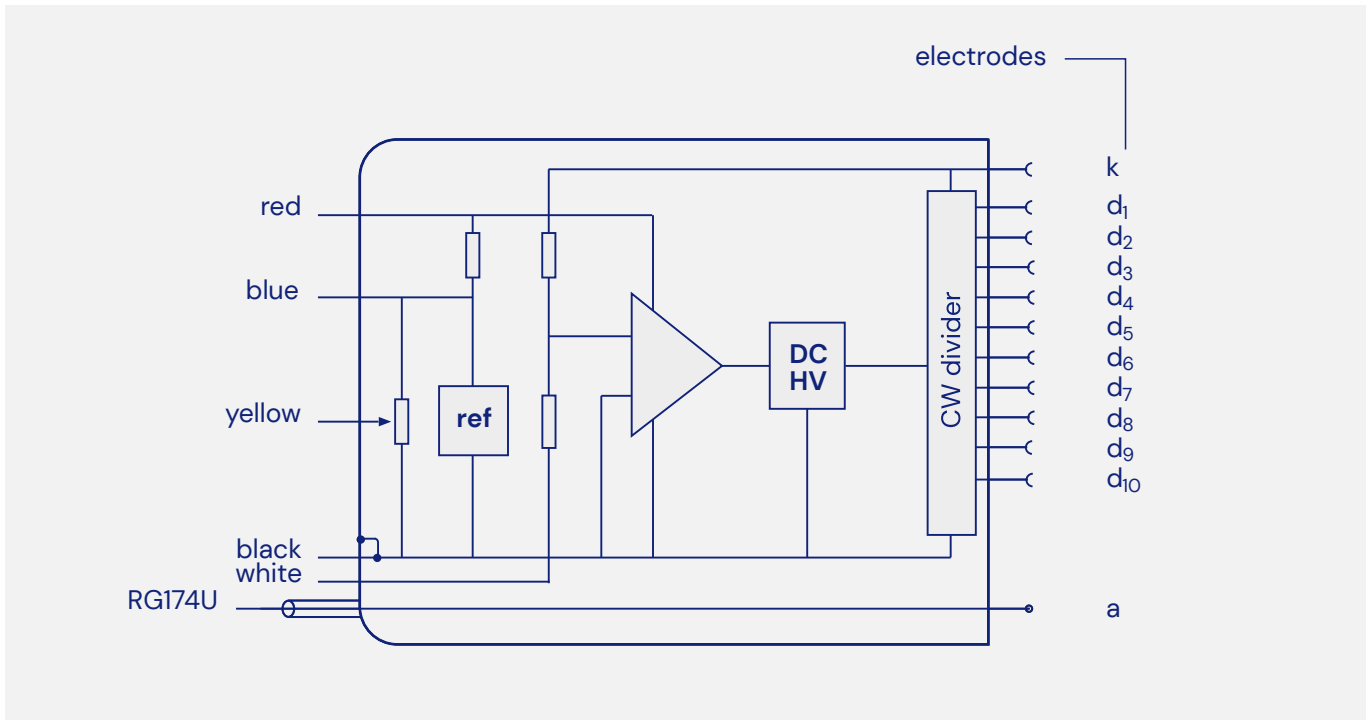

Example of output voltage with 1.2 volts applied to control (white) wire

CONTACT	ELECTRODE	VOLTAGE	CONTACT	ELECTRODE	VOLTAGE
1	d ₁	-1000	7	d ₇	-400
2	d ₂	-900	8	d ₈	-300
3	d ₃	-800	9	d ₉	-200
4	d ₄	-700	10	d ₁₀	-100
5	d ₅	-600	11	a	0
6	d ₆	-500	14	k	-1200

PS1809 DATA SHEET

PHOTOMULTIPLIER POWER BASE (NEGATIVE)



SENS - TECH

VOLTAGE DISTRIBUTION

The photomultiplier pin configuration compatible with this power base is given below. Note that an anode load resistor is not included.

view from below



'ic' indicates an internal connection

k	d ₁	d ₂	d ₉	d ₁₀	a
2/12 V	1/12 V	1/12 V	1/12 V	
note: V is the high voltage, HV					

SLEEP MODE

The power consumption can be reduced by half to one third of its normal level by activating the sleep mode. This is done by taking the control voltage (white) to 0 V.

PROGRAMMING OPTIONS

Internal potentiometer
(access from back of power supply, clockwise to increase HV)

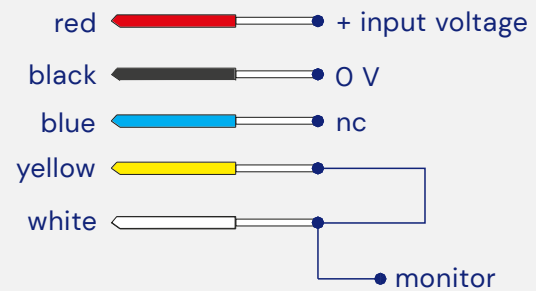

External potentiometer (the internal potentiometer must be set fully clockwise)

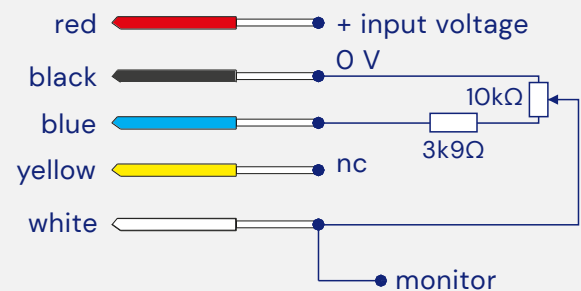

External voltage

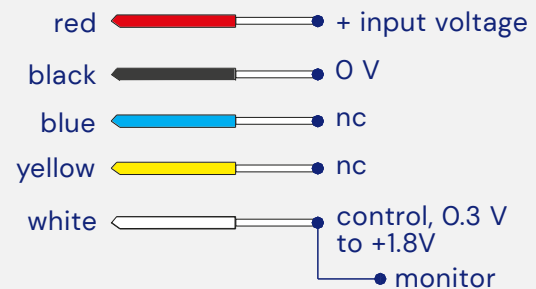

nc: no connection - isolated lead

Voltage monitor: 1/1000 of the HV applied to photomultiplier

PS1809 DATA SHEET

PHOTOMULTIPLIER POWER BASE (NEGATIVE)



SENS - TECH

OUTLINE DRAWING MM

All input connections are 7/0.2 PVC covered, 0.45m in length. The anode lead is RG174U, also 0.45m in length.

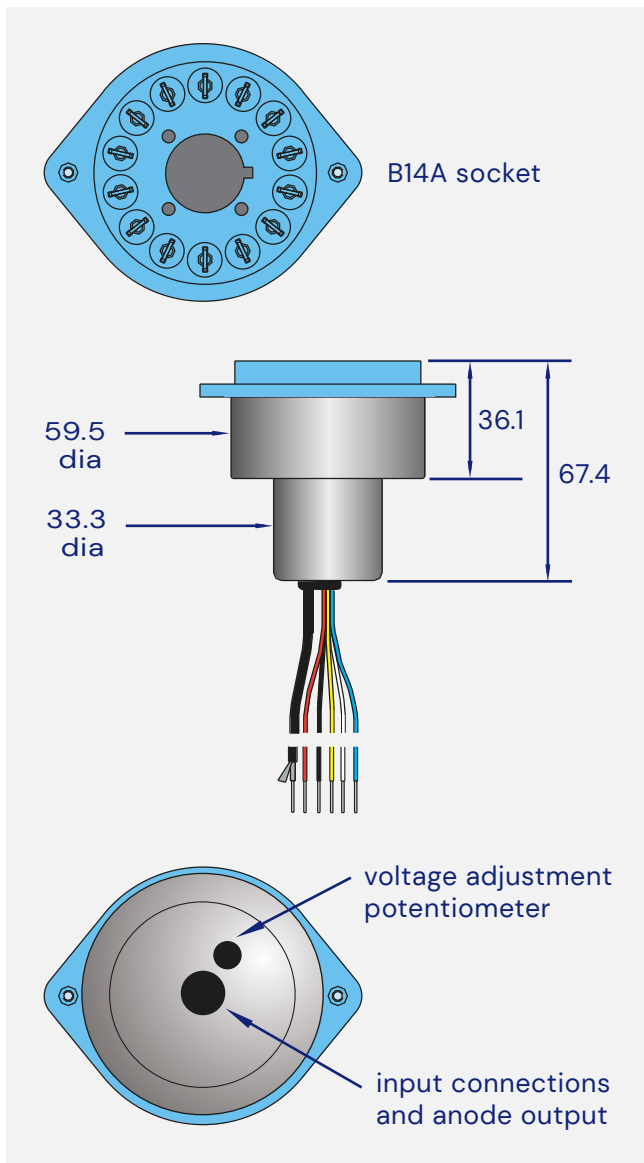

ORDERING INFORMATION

ITEM	ORDERING CODE
PS1809, +5 V, flange	PS1809/5F
PS1809, +12V, flange	PS1809/12F

WARNING

High voltages generated by these products present an electrical shock hazard and appropriate precautions must be taken. They must be installed by qualified personnel and operated within the specified ratings.

The PS1809 is despatched with the internal potentiometer set to zero.

Do not operate outside the ratings limits. This may result in loss of performance or permanent damage to the PS1809. Do not exceed the ratings of the photomultiplier as this may damage the photomultiplier and the power supply.